

FERMAT  *Ultimate Grinding*

GRINDING  
MACHINES

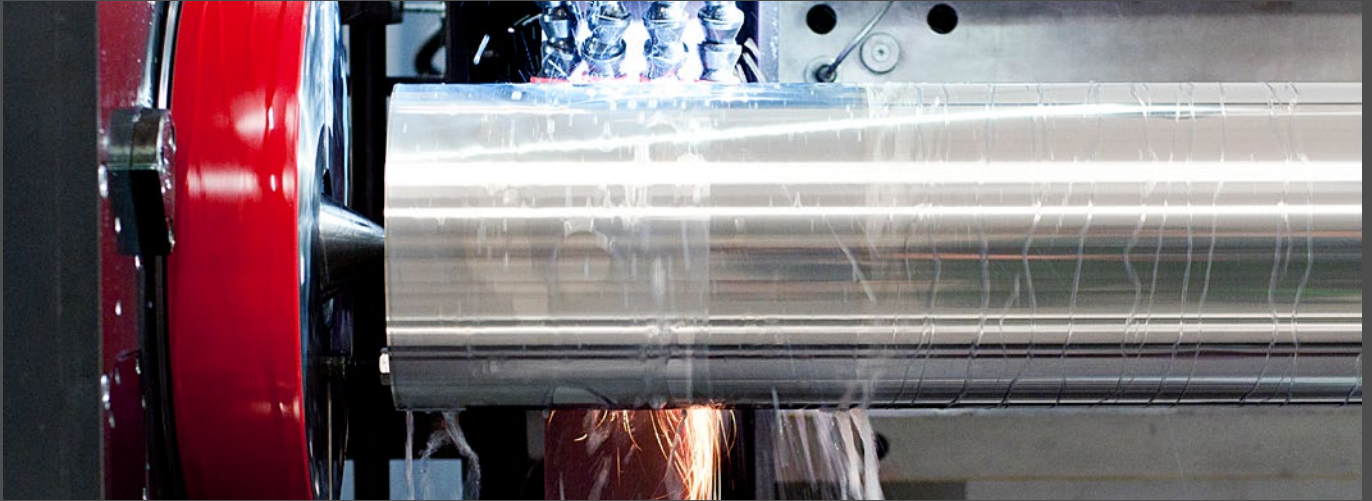

CYLINDRICAL  
GRINDING  
MACHINES

# FERMAT FAST FACTS

FERMAT MACHINERY

**500**  
Number of employees  

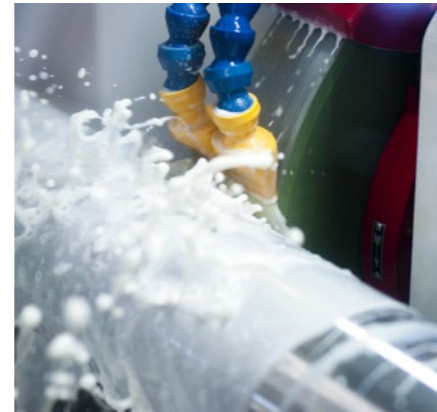

**TOP**  
SIEMENS Seller



**80€** mill.  
Annual sales in 2020

**1901**  
Oldest member of FERMAT Group

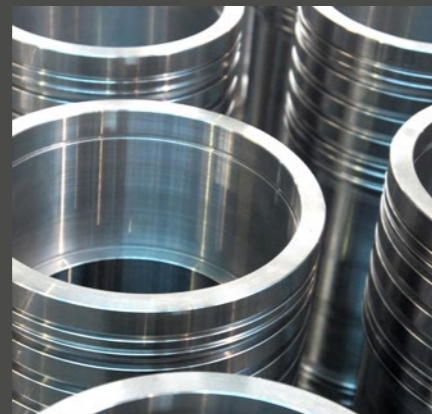
**8**  
Branches in Czech Republic  

**100+**  
Annual production/sold machines

**1**  
Micron (1 μm) has the most accurate production machine from our machining shop

**5**  
Football playgrounds would fit in floor space of FERMAT Production facilities  



# CONTENT

CYLINDRICAL GRINDING MACHINES

ABOUT US ..... 4  
About the company FERMAT

<b>NEW MODELS</b>	<b>BHC / BHC HD</b> ..... 8
	<b>BHCR / BHCR HD</b> ..... 12
	<b>BHM / BHMR</b> ..... 16

BASIC DESIGN ELEMENTS OF THE MACHINE ..... 23  
Beds and Tables, Grinding Wheel Head, Work Head, Tailstock, Ball screws, Other Components, Electric Equipment, Control Systems and Drives

ACCESSORIES AND POSSIBLE OPTIONS ..... 28

COMPONENTS ..... 36

<b>BESTSELLERS</b>	<b>BUC E</b> ..... 38
	<b>BUB E</b> ..... 40

OTHER PRODUCTS ..... 42  
Table Type Horizontal Boring Mills, Floor Type Horizontal Boring Mills

REFERENCES ..... 44

# ABOUT US

## FERMAT MACHINERY

The present-day FERMAT is an established machine tool brand, with its production and technical base in the Czech Republic. The product portfolio consists primarily of horizontal boring machines, milling machines and grinders. From its very foundation until today, the companies in the FERMAT group have been actively led by its owners, which enables us to be a stable and flexible partner for our customers.

The history of the oldest member of the FERMAT group dates back to 1901. We're very proud of this tradition which, together with our name, creates a strong commitment to deliver the highest product and service quality to our customers. In addition to many years' experience with machine tools, as well as their construction, technology and production, FERMAT's success is based on the principles of a long-term partnership with our customers and the active solving of their needs, our machines' high innovation level, a fast response time, delivery and flexibility. Last but not least, we offer excellent customer support, both pre-sales (e.g. logistics and financial support services) and after-sales (customer care). As a result of this, the

FERMAT group belongs among the world's leading machine tool manufacturers. After successful growth and stabilisation in Europe, FERMAT continues to increase its global footprint. The FERMAT group's operations currently reach from the USA, through many locations and partners in Europe, to growing markets in Asia.

During the last great crisis in the years 2008 to 2009, FERMAT not only maintained its leading position, but even acquired several traditional manufacturing companies, which demonstrates its long term focus and strong financial position. We used the period of declining business volume during the Covid-19 pandemic to even better set our production and logistics processes, as well as focus on collaboration with customers using modern technologies; therefore, today we are ready to communicate online with customers around the world at a very professional level.

Today, our experienced engineers and technicians manufacture more than 100 machines annually. You will find us at leading international engineering trade fairs around the world.



# ABOUT US

## FERMAT MACHINE TOOL, LTD.

*Dear business partners and friends, I am pleased that we meet on the pages of our catalogue once again.*

*We have a period behind us that probably wasn't easy for anyone, and it fills me all the more with joy that the FERMAT group and our FERMAT Machine Tool s.r.o. passed through this period not only without losses, but also stronger, more modern and even better prepared for our customers' demanding requirements.*

*Just before the outbreak of the global Covid-19 epidemic, we managed to finish and completely move our production, including all design, sales and administrative facilities, into our new hall on the outskirts of Prague, in Radějovice. This new facility was completely designed especially for the production of our most accurate machines, and it's already helping us to even better achieve their highest precision and quality. Many of you already well know that FERMAT Machine Tool has long been a stable and first-rate manufacturer in the field of cylindrical grinders, as well as a major global player and supplier to the most prestigious engineering manufacturers.*

*We built this reputation by honest work, starting with good ideas, a quality design, and most importantly the very precise processing of every part used during the manufacture of our machines. Together with the use of first-rate components from renowned manufacturers in the Czech Republic and around the world, our machines are a guarantee of long-term reliability and the required precision. We choose all our suppliers carefully, and collaborate only with those who are prepared to supply the required components*

*in top quality. Therefore, in our machines you will find only the best that the current market has to offer. It is also no secret that many suppliers closely collaborate with our design department and PLC programmers when developing their components. This is one of the reasons why our machines are controlled very intuitively, so that they perfectly suit their operators.*

*Our sales team, in collaboration with technology, is ready to offer you a unique solution for your needs, tailored to your ideas. The quality of our machines, and perfect communication with customers, is certainly also evidenced by the fact that the majority of our customers are also our very stable business partners, and in many of their companies you'll often find much more than one of our machines.*

*Although we value every one of our customers, these ones in particular fill us with a feeling of a job well done, and help us commit to being an even better supplier in the future. Excellent relationships with our customers are the greatest motivation for the FERMAT Machine Tool team.*



*M. Bureš* Ing. Michal Bureš, MBA  
Chief Executive Officer and Co-owner  
of FERMAT Machine Tool, Ltd.



# INDUSTRIAL APPLICABILITY



FOR MORE INFORMATION, SEE OUR WEBSITE

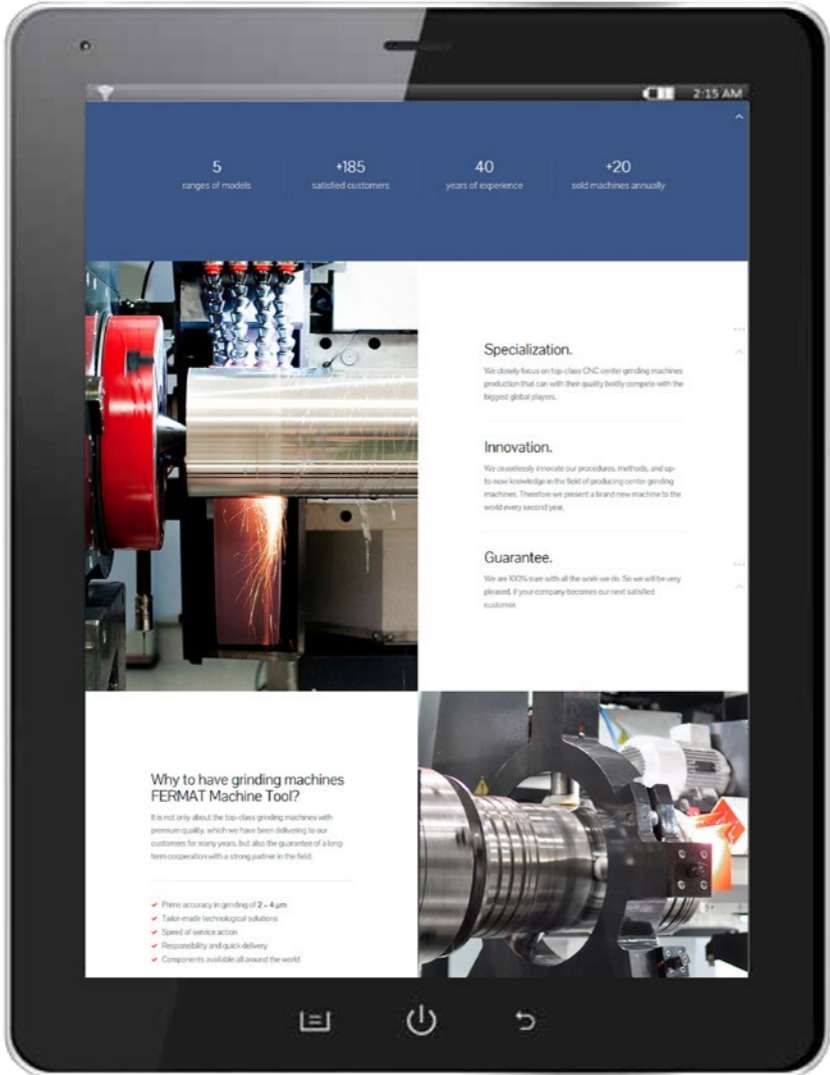

[www.fermatmachinetool.com](http://www.fermatmachinetool.com)

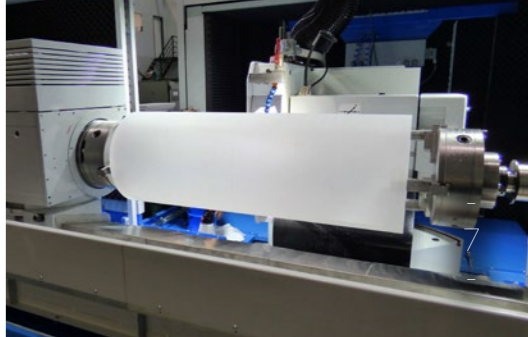
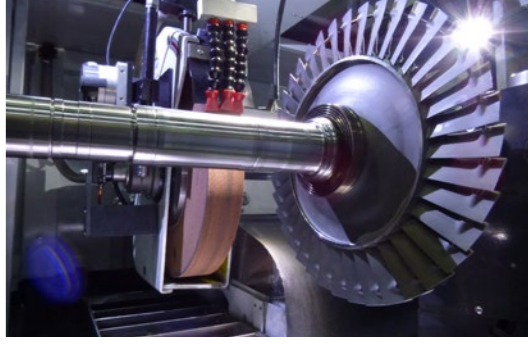
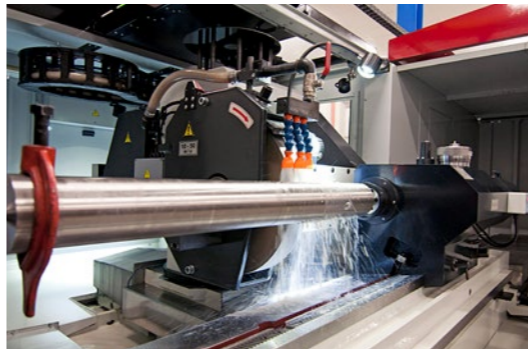
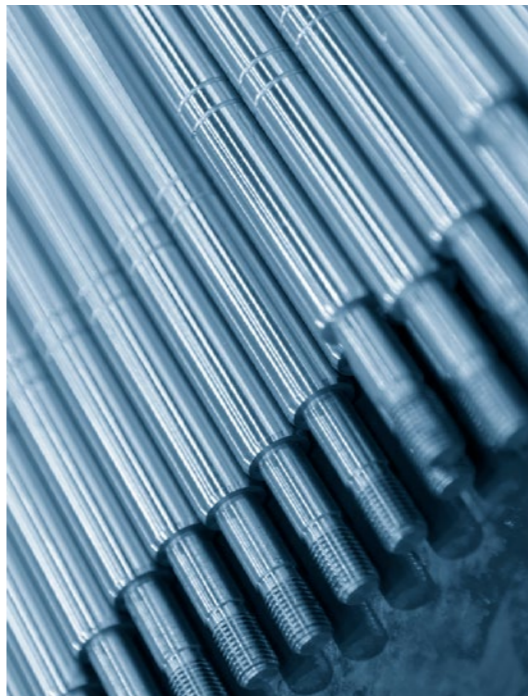

# BHC / BHC HD

BHC IS A FULLY CNC CONTROLLED CYLINDRICAL GRINDING MACHINE DESIGNED FOR LONGITUDINAL AND PLUNGE-CUT GRINDING OF CYLINDRICAL AND CONICAL EXTERNAL SURFACES, OR WITH INTERNAL GRINDING ATTACHMENT FOR GRINDING OF CYLINDRICAL AND CONICAL INTERNAL SURFACES.

Grinding of face surfaces can be performed by the side of grinding wheel or its circumferential surface with using work head swivel.



See BHC video

Grinding machine series BHC can be used particularly in single-part and series production for grinding of workpieces up to **4000 kg (optionally 5000 kg - HD)**. The machine is produced with higher accuracy to enable grinding of single diameters in the tolerance of IT 4 and higher. The standard version of the machine is equipped with a Siemens 840D sl or Siemens 828D sl control system. The standard machine meets CE standards and is supplied with essential accessories and a guarantee of 1 year.

# BHC / BHC HD

## MACHINE DESIGN:

- ✓ highly stable bed with reinforcement,
- ✓ excellent friction characteristics of Teflon,
- ✓ according to the CE standard,
- ✓ CNC control systems (SIEMENS, B&R, Fanuc),
- ✓ digital AC servomotors,
- ✓ controlled axis X (grinding wheelhead in-feed), Z (table feed),
- ✓ hand-wheel for axis X and Z setting,
- ✓ equipped with fully covering and automatic controlled doors,
- ✓ telescopic covers,
- ✓ cooling with belt and magnetic filter,
- ✓ robust and rigid duo table.

The machines are additionally equipped and designed according to specific needs of the customer and taking into account the materials to be ground or the selected machining technology.



# BHC / BHC HD

CYLINDRICAL GRINDING MACHINES TYPE

PARAMETERS	Units	Design version
<b>Working range</b>		
Swing diameter	mm (in)	630 (24,8) / 850 (33,5) / 1000 (39,4) / 1200 (47,3)*
Distance between centers	mm (in)	2000 (78,7) / 3000 (118,1) / 4000 (157,5) / 5000 (196,9) / 6000 (236,2)
Max. weight of workpiece - between centers	kg (lb)	4000 (8800)
Max. weight of workpiece - between centers - heavy duty machine	kg (lb)	5000 (11000)
Max. weight of workpiece-with live spindle (incl. clamp)	kg (lb)	300 (660) / HD: 400 (880)
<b>Grinding unit – Axis X</b>		
Minimum programmable feed	mm (in)	0,0005 (0,00002)
Maximum speed	m.min <sup>-1</sup> (in/min)	10 (393,7)
<b>Table – Axis Z</b>		
Minimum programmable table feed	mm (in)	0,001 (0,00004)
Maximum speed	m.min <sup>-1</sup> (in/min)	10 (393,7)
<b>Grinding Wheel head</b>		
Grinding wheel dimensions (dia. x width x bore)	mm (in)	Ø 750 x 100 x Ø 305 (Ø 29,5 x 3,9 x Ø 12)
Diameter of worn-out wheel	mm (in)	Ø 570 (Ø 22,4)
Maximum grinding wheel width	mm (in)	125 (4,92)
Grinding wheel peripheral speed	m/s	10 - 50
Wheel head swivel	°	+30/-30
Wheel head motor power	kW (hp)	18,5 (24,8)
<b>Work head</b>		
Work head swivel	°	0 - 90
Work head swivel – heavy duty	°	0
Work head spindle taper bore	-	Morse 6 ISO 296-1991
Work head spindle nose	-	A 2-6 ISO 702-1-1992
<b>Tailstock</b>		
Tailstock barrel taper bore	-	Morse 6 ISO 296-1991
Tailstock barrel stroke	mm (in)	70 (2,8)
Cross motion of tailstock center – cylindrical correction	mm (in)	±0,8 (0,031)
Tailstock clamping force	N	300-20000
<b>Other specifications</b>		
Length of machine	mm (in)	8500 (335) / 10600 (417) / 13000 (512) / 15500 (610) / 18000 (709)
Width of machine	mm (in)	4400 (173)
Height of machine	mm (in)	2550 (100)
Weight of machine	kg (lb)	17000 (37400) / 20000 (44000) / 23700 (52140) / 26000 (57200) / 28000 (61600)
Control system	-	Siemens 840D sl Siemens 828D sl
Drives	-	Sinamics
Ball screws	-	KSK Kuřim Shuton
Cooling and filtration	-	Astos Aš UMT LEHMANN
Lubrication	-	Tribotec
Pneumatic equipment	-	FESTO
<b>Machine working accuracy according to ISO 2433 (depending on grinding materials and machining technology)</b>		
Machine working accuracy (without in-process gauge)	-	IT 4
Surface roughness	Ra	0,2 (0,05)
Roundness of workpiece	mm (in)	0,002 (0,0001)

\*special version



# BHCR / BHCR HD

BHCR (HD) IS A FULLY CNC-CONTROLLED CYLINDRICAL GRINDING MACHINE WITH AUTOMATIC POSITIONING OF THE GRINDING WHEEL HEAD, DESIGNED FOR GRINDING CYLINDRICAL AND CONICAL EXTERNAL SURFACES OR, WITH EQUIPMENT FOR INTERNAL GRINDING, FOR GRINDING OF INTERNAL SURFACES WITH THE PLUNGE CUT OR LONGITUDINAL GRINDING METHOD.

Grinding of face surfaces can be performed by the side of the grinding wheel or its circumferential surface with inclined drive headstock. The automatic positioning grinding head on the vertical axis B can be equipped with up to 3 tools.

BHCR (HD) CNC grinder can be used particularly in the single-part and series production for grinding workpieces weighing up to **4000 kg (optionally 5000 kg - HD)**.

On this machine customers typically achieve an accuracy of up to 0,004 mm, or the machine can be produced with an increased accuracy of up to 0,002 mm.

The standard version of the machine is equipped with a Siemens 840 D sl control system.

The machine meets CE standards and is supplied with basic equipment and a guarantee of 1 year.

The machine is additionally equipped and designed according to specific needs of the customer and taking into account the materials to be ground or the selected machining technology.

# BHCR / BHCR HD

## MACHINE POSSIBILITIES:

- ✓ program controlled rotation of the B axis - grinding wheel head along the vertical axis,
- ✓ external and internal grinding of workpieces clamped between centers or by using a chuck in work head,
- ✓ sequential plunge grinding or longitudinal grinding with a moving table, and plunge grinding with a stationary or oscillating table,
- ✓ wheel head can be equipped with up to three tools (grinding wheel/ spindle for internal grinding/ superfinish attachment),
- ✓ significantly expands the technological possibilities of the grinding machine,
- ✓ this design increases the ability to grind with more tools in one clamping arrangement,
- ✓ precise and efficient grinding of complex workpieces in both serial and small-lot production.



# BHCR / BHCR HD

CYLINDRICAL GRINDING MACHINES TYPE

PARAMETERS	Units	Design version
<b>Working range</b>		
Swing diameter	mm (in)	630 (24,8) / 850 (33,5) / 1000 (39,4) / 1200 (47,3)*
Distance between centers	mm (in)	2000 (78,7) / 3000 (118,1) / 4000 (157,5) / 5000 (196,9) / 6000 (236,2)
Max. weight of workpiece - between centers	kg (lb)	4000 (8800)
Max. weight of workpiece - between centers – heavy duty machine	kg (lb)	5000 (11000)
Max. weight of workpiece-with live spindle (incl. clamp)	kg (lb)	300 (660) / HD: 400 (880)
<b>Grinding unit – Axis X</b>		
Minimum programmable in-feed	mm (in)	0,0005 (0,00002)
Maximum speed	m.min <sup>-1</sup> (in/min)	10 (393,7)
<b>Table – Axis Z</b>		
Minimum programmable table feed	mm (in)	0,001 (0,00004)
Maximum speed	m.min <sup>-1</sup> (in/min)	10 (393,7)
<b>Grinding Wheel head - Axis B</b>		
Grinding wheel dimensions (dia. x width x bore)	mm (in)	Ø 750 x 100 x Ø 305 (Ø 29,5 x 3,9 x Ø 12)
Diameter of worn-out wheel	mm (in)	Ø 570 (Ø 22,4)
Maximum grinding wheel width	mm (in)	125 (4,92)
Grinding wheel peripheral speed	m/s	10 - 50
Wheel head swivel	°	+45/-225
Minimum programmable rotation feed	°	0,0001
Wheel head motor power	kW (hp)	18,5 (25)
<b>Work head</b>		
Work head swivel	°	0 - 90
Work head swivel – heavy duty	°	0
Work head spindle taper bore	-	Morse 6 ISO 296-1991
Work head spindle nose	-	A 2-6 ISO 702-1-1992
<b>Tailstock</b>		
Tailstock barrel taper bore	-	Morse 6 ISO 296-1991
Tailstock barrel stroke	mm (in)	70 (2,8)
Cross motion of tailstock center - cylindrical correction	mm (in)	±0,8 (0,031)
Tailstock clamping force	N	300-20000
<b>Other specifications</b>		
Length of machine	mm (in)	8500 (335) / 10600 (417) / 13000 (512) / 15500 (610) / 18000 (709)
Width of machine	mm (in)	4400 (173)
Height of machine	mm (in)	2550 (114)
Weight of machine	kg (lb)	18500 (40785) / 21500 (47399) / 25200 (55556) / 27500 (60627) / 29500 (65036)
Control system	-	Siemens 840D sl
Drives	-	Sinamics
Ball screws	-	KSK Kuřim Shuton
Cooling and filtration	-	Astos AŠ UMT LEHMANN
Lubrication	-	Tribotec
Pneumatic equipment	-	FESTO
<b>Machine working accuracy according to ISO 2433 (depending on grinding materials and machining technology)</b>		
Machine working accuracy (without in-process gauge)	-	IT 4
Surface roughness	Ra	0,2 (0,05)
Roundness of workpiece	mm (in)	0,002 (0,0001)

\*special version

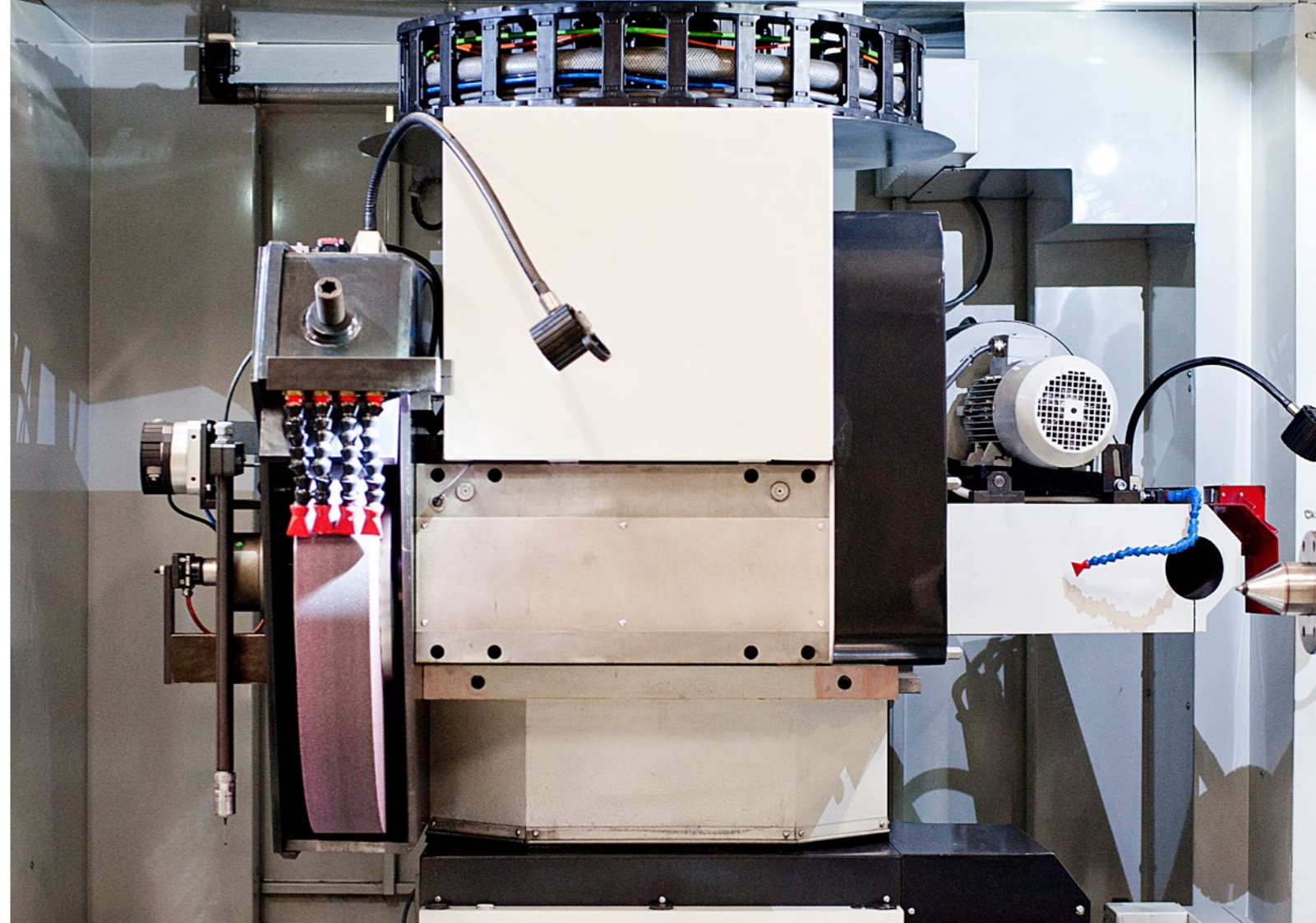

## ROTARY AXIS B WITH POSSIBLE TOOLS

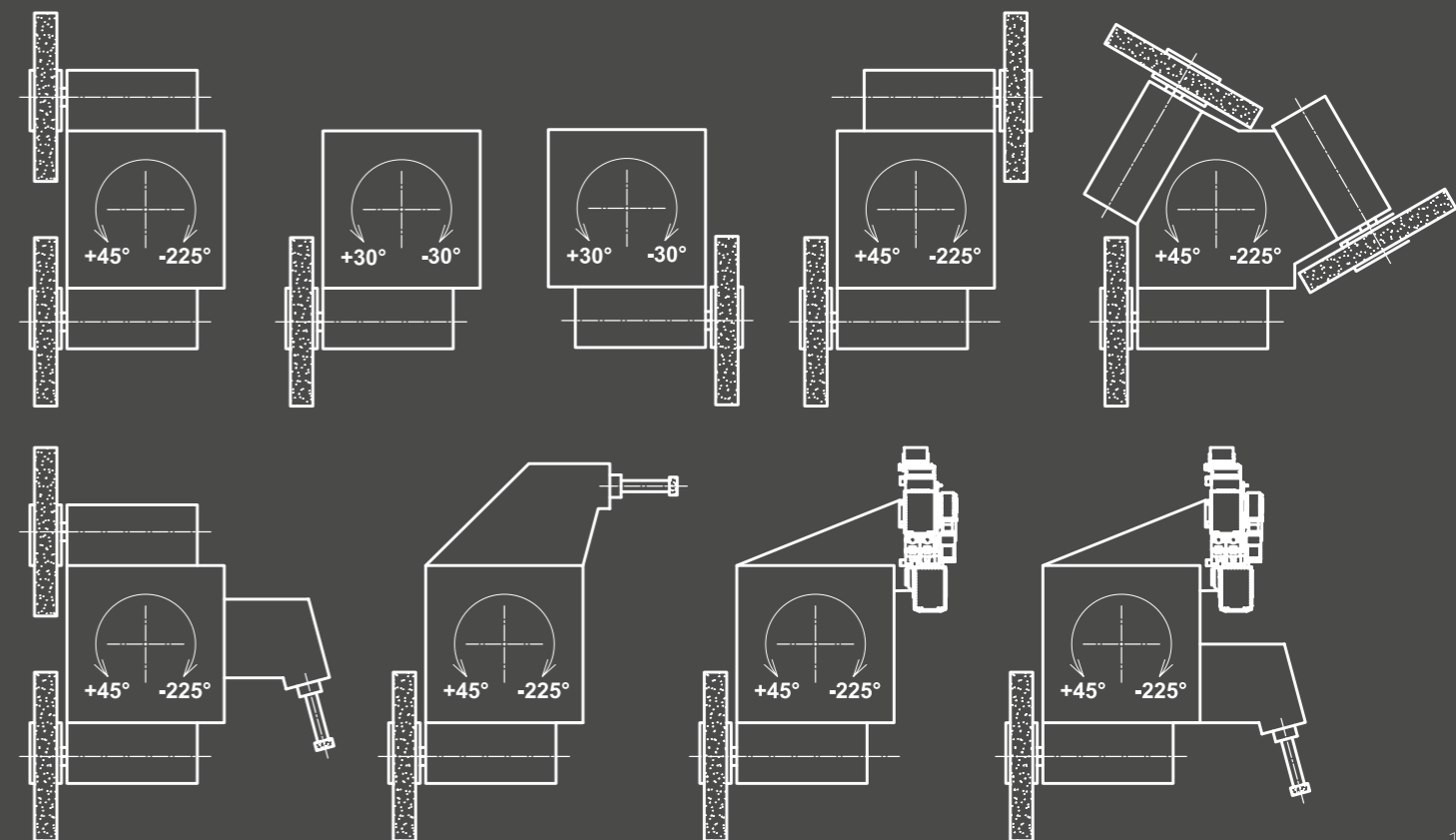



# BHM

BHM IS A FULLY CNC CONTROLLED GRINDING MACHINE DESIGNED FOR LONGITUDINAL AND PLUNGE-CUT GRINDING OF CYLINDRICAL AND CONICAL EXTERNAL SURFACES, OR WITH INTERNAL GRINDING ATTACHMENT FOR GRINDING OF CYLINDRICAL AND CONICAL INTERNAL SURFACES.

Grinding of face surfaces can be performed by the side of grinding wheel or its circumferential surface using work head swivel.

Grinding machine series BHM can be used particularly in single-part and series production for grinding of workpieces up to 850 kg between centers and 1000 kg between centers in rests. The machine is produced with higher accuracy to enable grinding of single diameters in the tolerance of IT 4 and higher. Standard version of the machine is equipped with a Siemens 840D sl or Siemens 828D sl control system,

alternatively B&R. The standard machine meets CE standards and is supplied with essential accessories and a guarantee of 1 year.

# BHM

## MACHINE DESIGN:

- ✓ highly stable bed with reinforcement,
- ✓ excellent friction characteristics of Teflon,
- ✓ according to the CE standard,
- ✓ CNC control systems (SIEMENS, B&R),
- ✓ digital AC servomotors,
- ✓ controlled axis X (grinding wheelhead in-feed), Z (table feed),
- ✓ hand-wheel for axis X and Z setting,
- ✓ equipped with fully covering and manually controlled doors,
- ✓ telescopic covers,
- ✓ cooling with belt and magnetic filter,
- ✓ robust and rigid duo table.

The machines are additionally equipped and designed according to specific needs of the customer and taking into account the materials to be ground or the selected Machining technology.

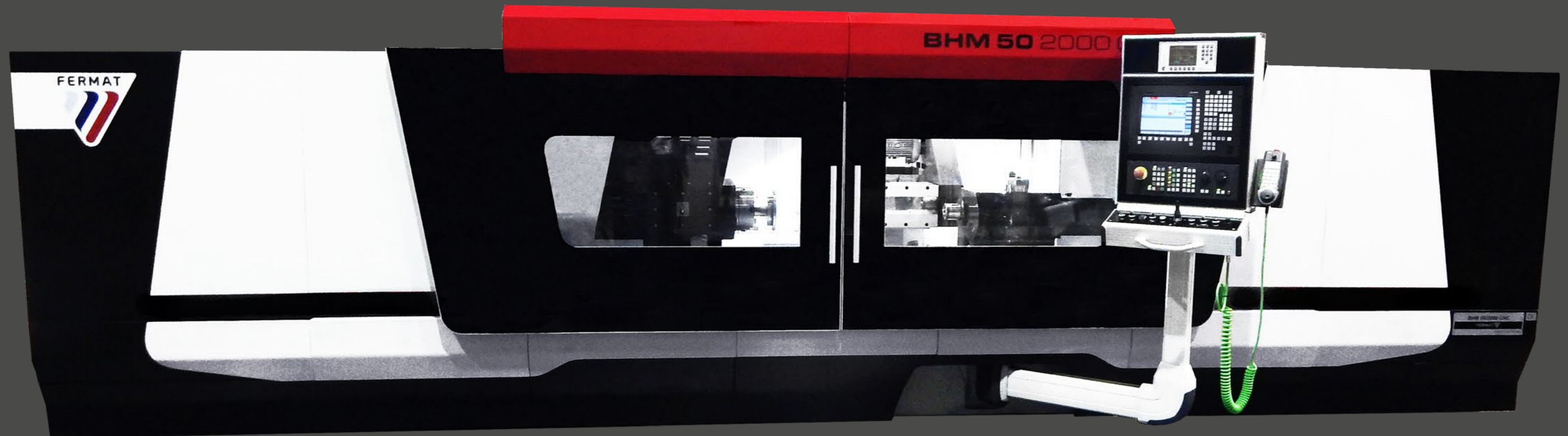

# BHM

## CYLINDRICAL GRINDING MACHINES TYPE

PARAMETERS	Units	Design version
<b>Working range</b>		
Swing diameter	mm (in)	500 (19,7) / 600 (23,6)
Distance between centers	mm (in)	1000 (39,4) / 1500 (59) / 2000 (78,7) / 3000 (118,1)
Max. weight of workpiece - between centres	kg (lb)	850 (1 874)
Max. weight of workpiece - between centres – in rests	kg (lb)	1 000 (2 205)
Max. weight of workpiece-with live spindle (incl. clamp)	kg (lb)	120 (265)
<b>Grinding unit – Axis X</b>		
Minimum programmable in-feed	mm (in)	0,0005 (0,00002)
Maximum speed	m.min-1 (in/min)	8 (0,31)
<b>Table – Axis Z</b>		
Minimum programmable table feed	mm (in)	0,001 (0,0004)
Maximum speed	m.min-1 (in/min)	8 (0,31)
<b>Grinding Wheel head</b>		
Grinding wheel dimensions (dia. x width x bore)	mm (in)	Ø 500 x 80 x Ø 203 (Ø 19,7 x 3,1 x Ø 8)
Diameter of worn-out wheel	mm (in)	Ø 380 (Ø 15)
Maximum grinding wheel width	mm (in)	125 (4,9)
Grinding wheel peripheral speed	m/s	10 – 50
Wheel head swivel (manually)	°	+15 / –180
Minimum programmable rotation feed	°	0,0001
Wheel head motor power	kW (hp)	11 (15)
<b>Other specifications</b>		
Length of machine	mm (in)	5100 (200,8) / 7400 (291) / 8300 (327) / 10000 (394)
Width of machine	mm (in)	3900 (154)
Height of machine	mm (in)	2400 (95)
Weight of machine	kg (lb)	8500 (18739) / 10000 (22046) / 12000 (26456) / 14000 (30865)
Control system	-	Siemens 828D sl / 840D sl B&R
Drives	-	Sinamics
Ball screws	-	KSK Kuřim Shuton
Cooling and filtration	-	Astos Aš UMT LEHMANN
Lubrication	-	Tribotec
Pneumatic equipment	-	FESTO
<b>Machine working accuracy according to ISO 2433 (depending on grinding materials and machining technology)</b>		
Machine working accuracy (without in-process gauge)	-	IT 4
Surface roughness	Ra	0,2 (0,05)
Roundness of workpiece	mm (in)	0,002 (0,0001)



# BHMR

BHMR IS A FULLY CNC-CONTROLLED CENTER GRINDER WITH AUTOMATIC POSITIONING OF THE GRINDING SPINDLE, DESIGNED FOR GRINDING CYLINDRICAL AND CONICAL EXTERNAL SURFACES OR, WITH EQUIPMENT FOR INTERNAL GRINDING, FOR GRINDING OF INTERNAL SURFACES WITH THE RECESS OR LONGITUDINAL GRINDING METHOD.

Grinding of face surfaces can be performed by the side of the grinding wheel or its circumferential surface with inclined drive headstock. The automatic positioning grinding head on the vertical axis B can be equipped with up to 3 tools.

BHMR CNC grinder can be used particularly in the piece and series production for grinding workpieces weighing up to 850 kg between centers and 1000 kg between centers in rests.

Customers typically achieve an accuracy of 0,004 mm on this machine. It can

also be produced with an increased accuracy up to 0,002 mm. The standard version of the machine is equipped with a Siemens 840 D sl control system.

The machine meets CE standards and is supplied with basic equipment and a guarantee of 1 year.

The machine is additionally equipped and designed according to specific needs of the customer and taking into account the materials to be ground or the selected machining technology.

PARAMETERS	Units	Design version
<b>Working range</b>		
Swing diameter	mm (in)	500 (19,7) / 600 (23,6)
Distance between centers	mm (in)	1000 (39,4) / 1500 (59) / 2000 (78,7) / 3000 (118,1)
Max. weight of workpiece - between centres	kg (lb)	850 (1 874)
Max. weight of workpiece - between centres - in rests	kg (lb)	1 000 (2 205)
Max. weight of workpiece-with live spindle (incl. clamp)	kg (lb)	120 (265)
<b>Grinding unit – Axis X</b>		
Minimum programmable in-feed	mm (in)	0,0005 (0,00002)
Maximum speed	m.min-1 (in/min)	8 (0,31)
<b>Table – Axis Z</b>		
Minimum programmable table feed	mm (in)	0,001 (0,0004)
Maximum speed	m.min-1 (in/min)	8 (0,31)
<b>Grinding Wheel head</b>		
Grinding wheel dimensions (dia. x width x bore)	mm (in)	Ø 500 (600) x 80 x Ø 203 (Ø 119,7 (23,6) x 3,1 x Ø 8)
Diameter of worn-out wheel	mm (in)	Ø 380 (Ø 15)
Maximum grinding wheel width	mm (in)	125 (4,9)
Grinding wheel peripheral speed	m/s	10 – 50
Wheel head swivel (Automatically)	°	+45 / –225
Wheel head motor power	kW (hp)	11 (15)
<b>Other specifications</b>		
Length of machine	mm (in)	5100 (200,8) / 7400 (291) / 8300 (327) / 10000 (394)
Width of machine	mm (in)	3900 (154)
Height of machine	mm (in)	2400 (95)
Weight of machine	kg (lb)	9000 (19841) / 10500 (23148) / 12500 (27557) / 14500 (31967)
Control system	-	Siemens 840D sl
Drives	-	Sinamics
Ball screws	-	KSK Kuřim Shuton
Cooling and filtration	-	Astos Aš UMT LEHMANN
Lubrication	-	Tribotec
Pneumatic equipment	-	FESTO
<b>Machine working accuracy according to ISO 2433 (depending on grinding materials and machining technology)</b>		
Machine working accuracy (without in-process gauge)	-	IT 4
Surface roughness	Ra	0,2 (0,05)
Roundness of workpiece	mm (in)	0,002 (0,0001)

## ROTARY AXIS B WITH POSSIBLE TOOLS

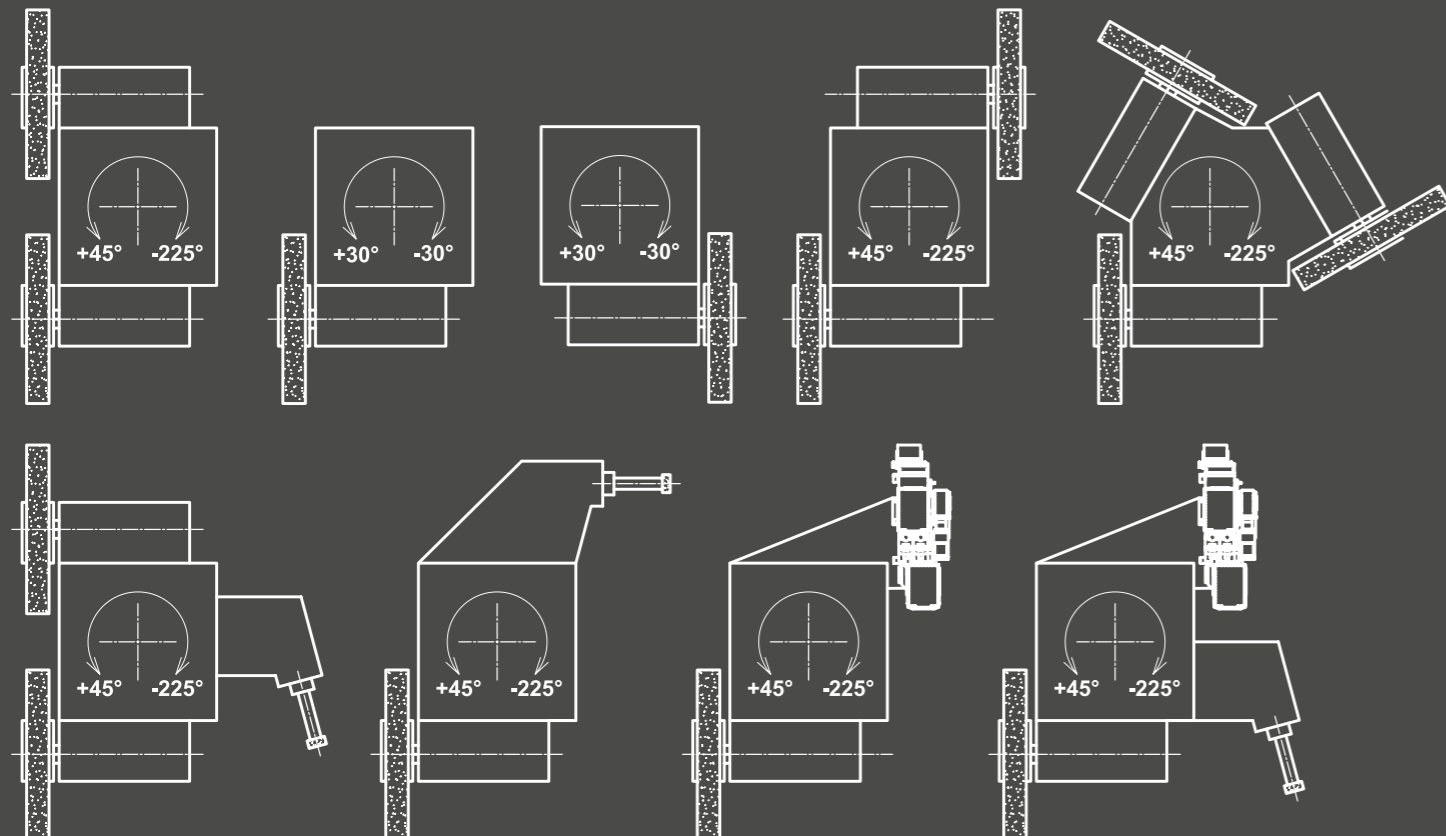

## MACHINE POSSIBILITIES:

- ✓ program controlled rotation of the B axis - grinding head along the vertical axis,
- ✓ external and internal grinding of workpieces clamped between centers or by using a chuck in work head,
- ✓ sequential plunge grinding or longitudinal grinding with a moving table, and plunge grinding with a stationary or oscillating table,
- ✓ wheel head can be equipped with up to three tools (grinding wheel/ spindle for internal grinding/ superfinish attachment),
- ✓ significantly expands the technological possibilities of the grinding machine,
- ✓ this design increases the ability to grind with more tools in one clamping arrangement
- ✓ precise and efficient grinding of complex workpieces in both serial and small-lot production.

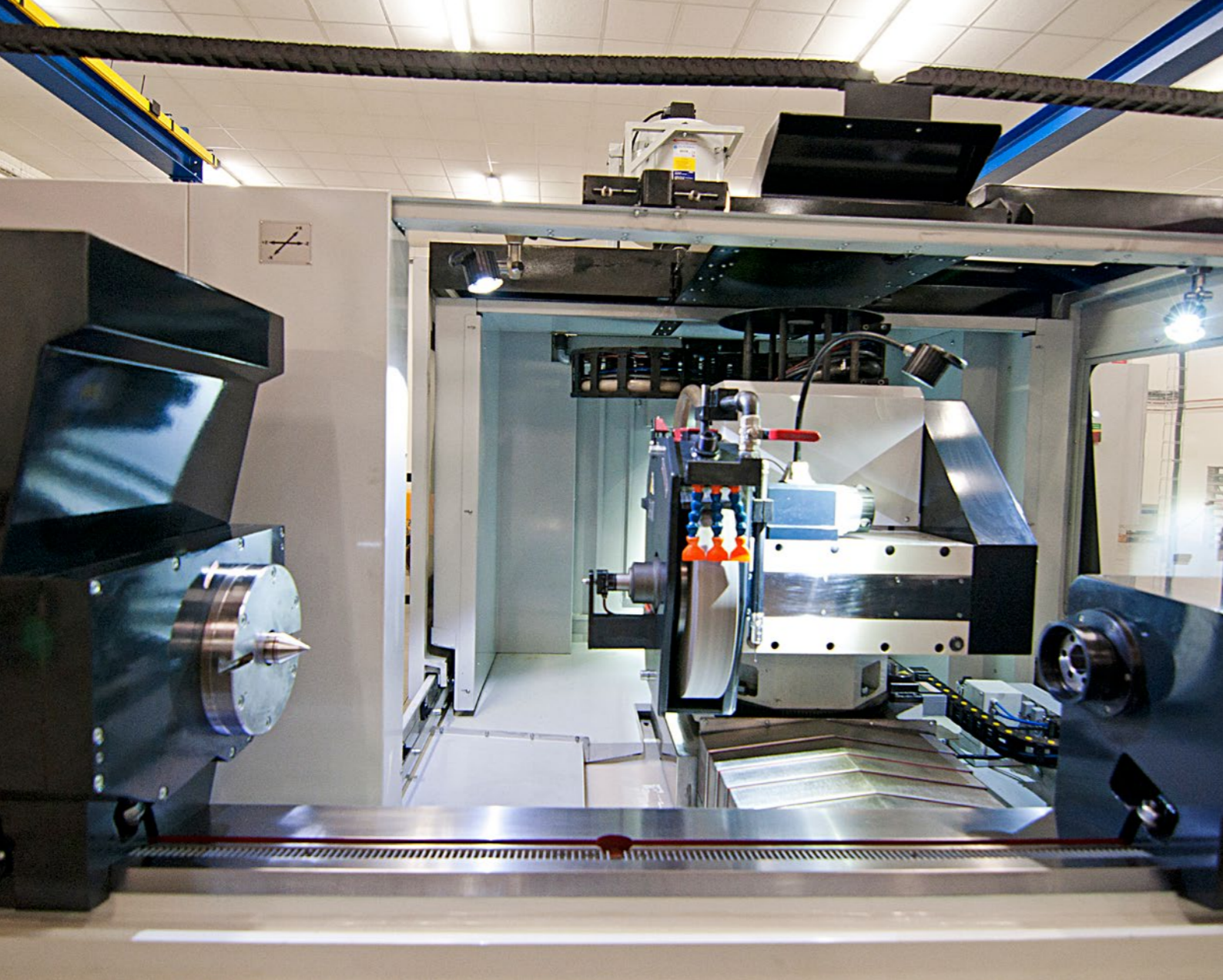

## BASIC DESIGN ELEMENTS OF THE MACHINE

### MACHINE BEDS AND TABLES

The machine beds as well as the table are made from high quality gray cast iron. Casting is always followed by an aging process and by roughing. The finishing process then continues with grinding of all guide-ways surfaces of the machine bed and table on a special slide-way grinding machine, and scraping for better sliding quality and more accurate guide-ways. Hand scraping is always with the done manually in accordance with a Protocol of accuracy, using precision templates for hand scraping the guide-ways of the table, beds, back plate and the grinding wheel-head. The bottom and top table is also ground in accordance with the Protocol of accuracy.

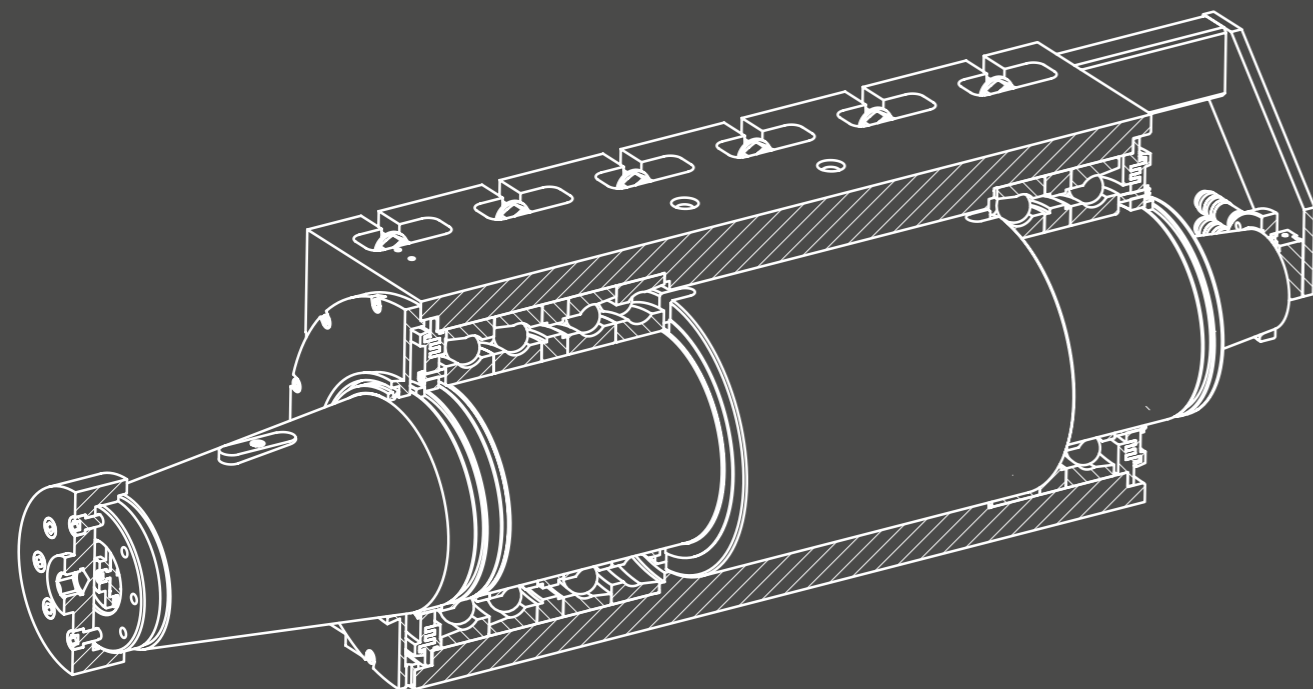

### GRINDING WHEEL HEAD

To achieve high radial and axial stiffness in the headstock, FKS 180 x 610 L (FKS 156 x 510 L) spindle angular contact bearings series 70 with increased rigidity (series EX) are used. The grinding wheel spindle has a group of four paired and preloaded bearings and spacers. The driving pulley also has a pair of preloaded bearings and spacers. Bearings are preloaded with a force 1.000 N. The circumferential speed range of 10 – 50 m/s is ensured by suitably selected components. The replaceable body of grinding wheel head is designed to provide minimum of 12 000 maintenance free working hours with peripheral runout less than 2  $\mu$ m.

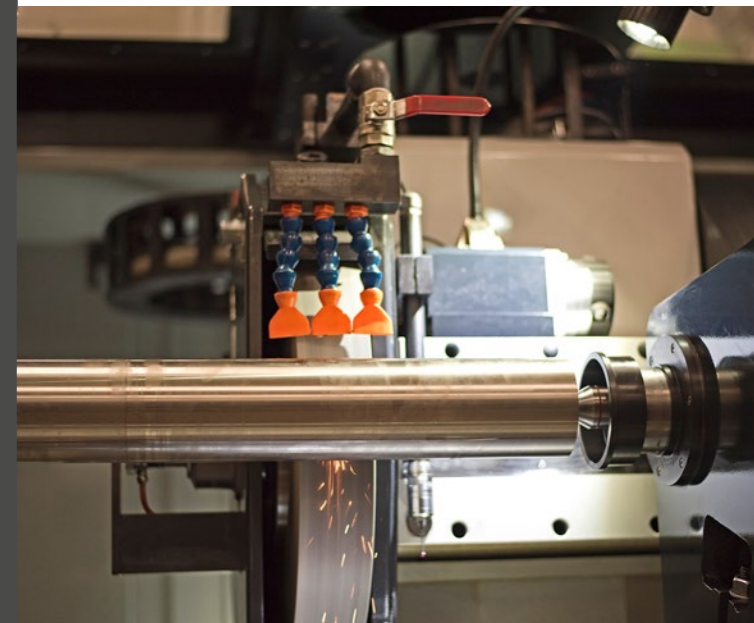

## WORK HEAD

The spindle of the work head is mounted in a high-precision paired bearings, fitted in the body of the headstock.

The shaft of spindle is heat-treated and ground for circumferential error of the outer centering surface and inner Morse cone for less than 5  $\mu\text{m}$ .

The design of the work head provides smooth speed control range from 4 to 250 rpm (4 - 560 rpm BHM / BHMR) using frequency converters and servomotors. Using a servomotor provides precise positioning.

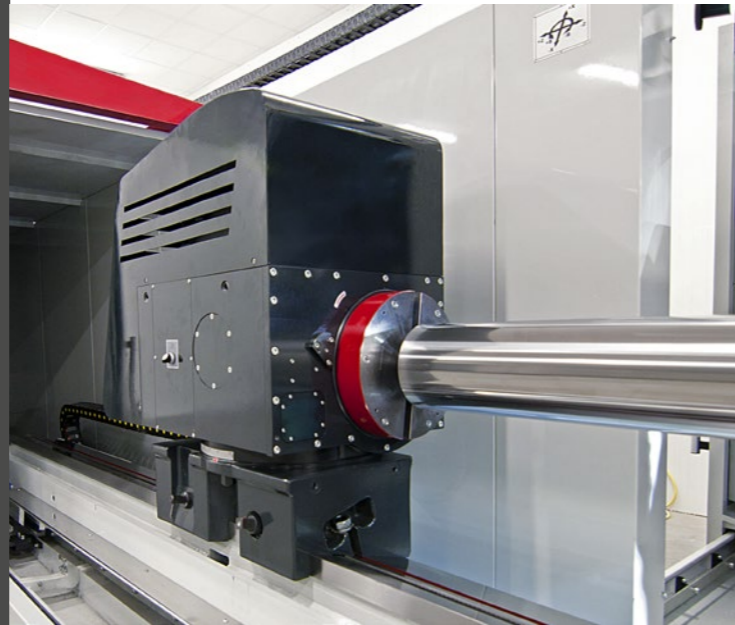

## TAILSTOCK

Tailstock sleeve is mounted in the body of tailstock using circular ball bearings with angular contact. This allows cross motion of tailstock centre and use of clamping force up to 12.000 N (4.000 N BHM / BHMR). Opening the tailstock sleeve is accomplished through hydraulic systems provided by well-known manufacturers. The tailstock clamp is released by compressed shop air.



## BALL SCREWS

Feed for X and Z axes is provided by high precision ball screws from the reputable Czech manufacturer (KSK Kuřim), or from abroad (Shuton). Ball screws are made in precision accuracy IT 1 for axis X and IT 3 for axis Z. Screws are mounted in accurate pillow blocks using preloaded INA radial-axial bearings. The usage of high quality ball screws ensures smooth and quiet running of the machine with the possibility of 1 $\mu\text{m}$  increment in both axes.



## COOLING AND FILTRATION

Equipment for filtration of the coolant is always supplied, and is selected according to the material to be ground. It is possible to supply equipment with a magnetic separator, belt filter, or a combination of both. The supplier of the cooling and filtering devices is ASTOS A $\text{S}$ . Cooling is provided by a pump (100 l / min) and bathing of the machine bed by another pump (25 l / min). Other types of cooling and filtration can be provided for specific applications.



## LUBRICATION

Lubrication of the guide-ways is provided by a pressure lubrication system. Other parts of the machine are lubricated by a TriboTec lubricating unit through the feeders. Lubricating of each axis is independent with the option to set according to traveled distance.



## PNEUMATIC COMPONENTS AND WIRING

The compressed air system of the machine serves to release the tailstock and to provide other functions (probe, cover of the internal grinding, cleaning of feedback spars). The machine is fitted with components provided by FESTO.



## GUIDE-WAY COVERS

Telescopic guide-way covers are used to ensure cleanliness of guide-ways, which are mostly metal (stainless steel), or alternatively for reasons of economy of space, rubber textile folded bellows are used instead.

The machine is fitted with components from HESTEGO or Tecnimetal.

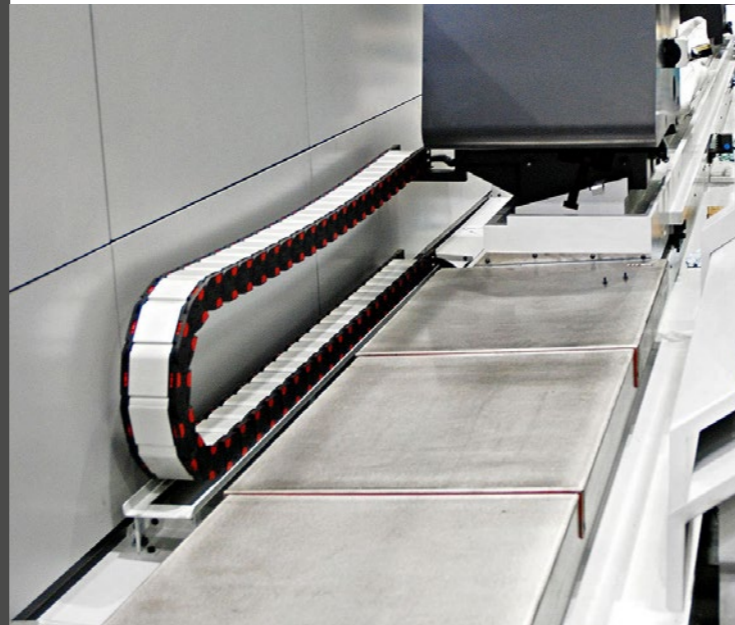

## PROTECTION ENCLOSURE

According to customer requirements, the machine can be fitted with a protection enclosure provided with sliding door to the working space and at the rear section of the machine with a partially enclosing cover, with an exhaust hood, or alternatively with a complete exhaust system.

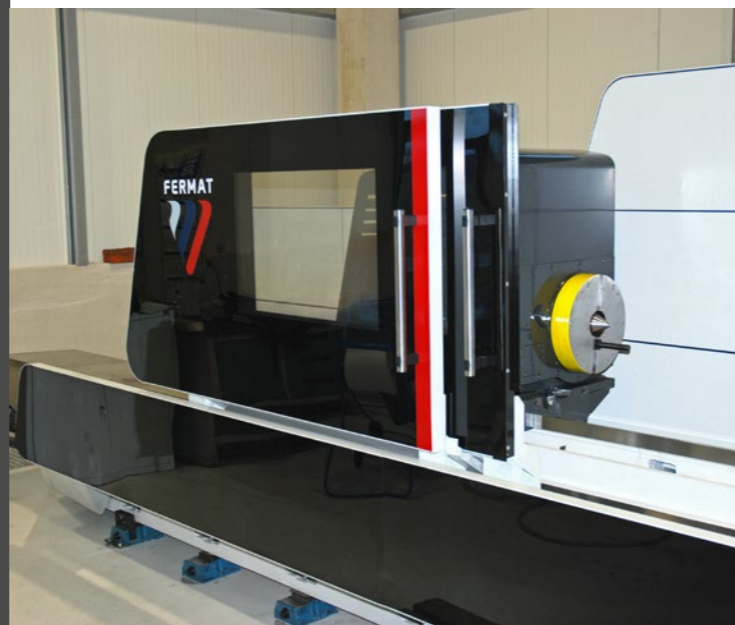

## SURFACE FINISHES

The inner surface of the grinding machine is provided with an oil resistant, corrosion proof coat of paint. The external surface is filled with a filler paste, sanded down and covered with a polyurethane coat in the color shade RAL 5010 combination with RAL 7035. In the case of a special customer request, we are prepared to change the standard color scheme to suit the customer's requirements.



## SINUMERIK

With over 50 years of experience in CNC technology, SINUMERIK CNCs guarantee maximum machining performance. Solution line offers the latest CNC system architecture as well as proven CNC features.



## ELECTRIC EQUIPMENT

All elements and components used meet all safety standards applicable in the EU and come from the world's leading manufacturers, such as Rittal (switchboard cabinets and control panels), Siemens (frequency converters), Schneider Electric, LAPPKABEL Schrack, and more.



## SINAMICS S120 AND DRIVE - CLIQ

The motors can be easily connected to the digital drives via DRIVE-CLiQ. In combination with the modular structure of the SINAMICS S120 drive system, this design is conceived to ensure very simple and rugged installation with minimum wiring overhead.



# SINUMERIK ONE

SINUMERIK ONE SETS STANDARDS IN MACHINING SPEED AND QUALITY.

Thanks to top PLC and CNC performance, this CNC system maximizes the productivity of machine tools. The integrated SIMATIC S7-1500F programmes the PLC cycle time up to ten times faster than its predecessor. SINUMERIK ONE increases productivity, speed, flexibility and efficiency of machine tools.

## CHARACTERISTICS:

- ✓ A new secure platform for the future
- ✓ With integrated PLC S7-1500F
- ✓ Up to 50 % higher NCK performance compared to 840D sl
- ✓ Significantly increased PLC performance (up to 10x) compared to 840D sl
- ✓ New operator components ITC2200 and MCP2200
- ✓ No data backup battery required
- ✓ Digital twin, complete PLC/NCK/HMI simulation
- ✓ Full support for digitalization and integration into corporate networks
- ✓ Full grinding support based on 840D sl predecessor



# SINUMERIK 840D SL

SINUMERIK® 840D SL PROVIDES AN OPEN, FLEXIBLE AND POWERFUL CNC SYSTEM WITH THE SINAMICS S120 DESIGN FOR UP TO 93 AXES.

Being decentralized, scalable, open, inter-connectable and with a wide range of functionality, the SINUMERIK 840D sl is suitable for use in almost every machining technology and it sets the standard in dynamics, precision and network integration. The SINUMERIK 840D sl offers you uniformity in its programming, operation and machining cycles. With its efficiency in programming, installation and commissioning, this CNC system platform is characterized by its optimum design, innovative NC functionality, communication and openness. The SINUMERIK 840D sl, available in several performance variants, can be

perfectly customized to practically every machine and machining technology in the manufacturing industry.

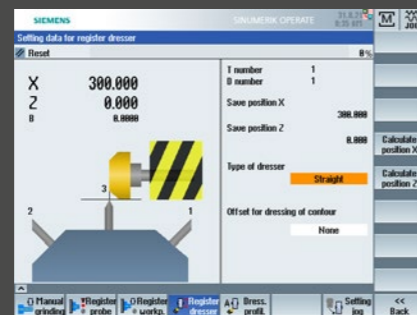
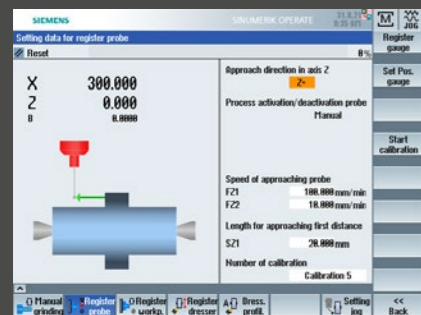
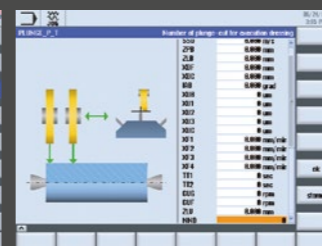
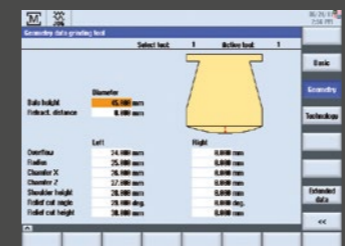
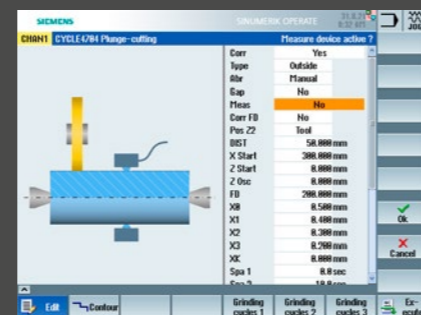
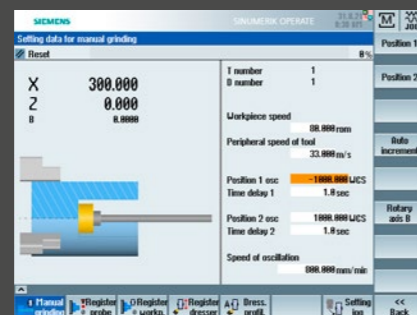
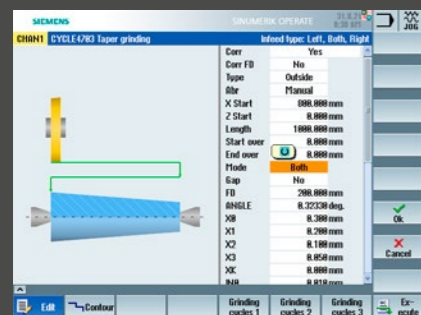

## TECHNOLOGY CYCLES:

- ✓ Longitudinal grinding with options for convex and concave grinding
- ✓ Plunge cut grinding
- ✓ Multiple plunge cut grinding with option taper grinding
- ✓ Ball grinding
- ✓ Dressing

## SINUMERIK 840D sl AT A GLANCE:

- ✓ Standard 10,4" TFT flat screen OP10C
- ✓ Number of axis and spindles is variable
- ✓ Language optionality
- ✓ Drives SINAMICS S120 connect via DRIVE – CLiQ
- ✓ Machine control Panel MCP 483
- ✓ Memory medium: USB
- ✓ DRIVE – CLiQ: ensures communication drives – controller
- ✓ Openness for bus PROFIBUS, (PROFINET)
- ✓ Ethernet RJ45: for service purposes, remote control and diagnostic or TeleService
- ✓ Remote control with handwheel HT2

## SPECIAL CHARACTERISTICS OF CYCLES

- Other hardware devices allow the use of special properties of grinding cycles.
- ✓ Measurement control, correction of final diameter possible
  - ✓ Asynchronous dressing of grinding tool
  - ✓ Touch trigger probe
  - ✓ Grinding acoustic sensor
  - ✓ Automatic compensation of grinding tool
  - ✓ Manual activation stroke to workpiece
  - ✓ Inside and outside grinding is possible

# SIEMENS SINUMERIK 828D SL

CONTROL SYSTEM 828D SL OFFERS HIGH MODULARITY, OPENNESS, AND FLEXIBILITY. IT IS INTEGRATED INTO THE DRIVE SYSTEM SINAMICS S120. TOGETHER WITH THE INTEGRATED PLC SYSTEM S7-200 IT IS CUSTOMIZED FOR MEDIUM AND HIGH REQUIREMENTS.



## BASIC CHARACTERISTICS:

- ✓ Control system for medium and highly complex tasks
- ✓ High performance and flexibility
- ✓ Compact control system for series conception of machines

# FERMAT FANUC

WITH OVER 60 YEARS OF EXPERIENCE, FANUC OFFERS THE WIDEST RANGE OF CNC SYSTEMS IN THE INDUSTRIAL SECTOR,

from cost-effective but powerful controllers to highly productive control systems for complex machines - with fast programming and easy operation to ensure the highest quality and short processing times.

## CHARACTERISTICS:

- ✓ Ready to use with integrated software package
- ✓ Best price-performance ratio
- ✓ Integrated FANUC Dual Check Safety function
- ✓ Workshop programming via iHMI, MANUAL GUIDE
- ✓ Integrated high-speed PMC
- ✓ Set of functions for high quality Grinding
- ✓ Maximum look-ahead queue of 400 blocks
- ✓ Identical operation, sustainability, network and PMC functions with the 30i-MODEL B family of systems
- ✓ iHMI offers intuitive and very user-friendly operation
- ✓ Perfectly matched components
- ✓ Additional functions for easy customisation



## PARAMETERS:

- ✓ Flat screen 10,4" with definition 800x600
- ✓ Maximum axis number 6
- ✓ User memory for programs c. 5 MB
- ✓ Drive system and motors SINAMICS S120, PLC S7-200
- ✓ Software version V04.07 SP3
- ✓ Support for scales Heidenhain for axis X and Z
- ✓ Ethernet X130 remote diagnostic
- ✓ USB, CF interface

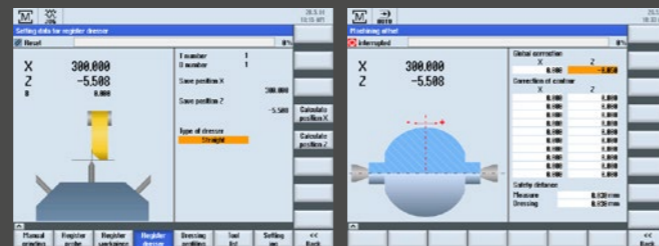

## SPECIAL TECHNOLOGICAL CYCLES

- ✓ Measurement control, correction of contour and final diameter
- ✓ Asynchronous dressing of grinding wheel
- ✓ Automatic compensation of grinding tool
- ✓ Manual activation sparking - out stroke

## TECHNOLOGICAL CYCLES:

- ✓ Longitudinal grinding
- ✓ Plunge-cut grinding
- ✓ Multi plunge-cut grinding
- ✓ Cone grinding
- ✓ Convex, concave grinding
- ✓ Plunge-cut in Z axis
- ✓ Ball grinding
- ✓ Automatic dressing
- ✓ Dressing in optional shape
- ✓ Axial probe
- ✓ Longitudinal grinding in X axis
- ✓ Radius internal

The CNC Series Fermat Fanuc provides the ideal basic solution for multiple control applications. Ready to use, it boasts latest generation hardware and a complete package of standard software. To maximise productivity on more specific applications, it can be easily customised using a range of additional functions. Combining unbeatable value for money with unrivalled performance and reliability, it includes features and functions usually associated with high performance systems.





# B&R AUTOMATION POWER PANEL 900

## CONTROL SYSTEMS AND DRIVES

The new drive generation from B&R provides a universal solution for any automation task in machine manufacturing. A new milestone on the path to „Perfection in Automation“.

The ACOPOSmulti drive system was developed exclusively by B&R and is produced in-house. The shortest path between development and production has proven to be the best solution over the years and makes up one of the pillars of our outstanding quality. There is just one company behind the entire palette of hardware and software, who carries sole responsibility - B&R.

An ACOPOSmulti drive system consists of a regeneration choke, line filter and three device groups - supply voltage modules,

auxiliary voltage modules and inverter modules.



Open rest

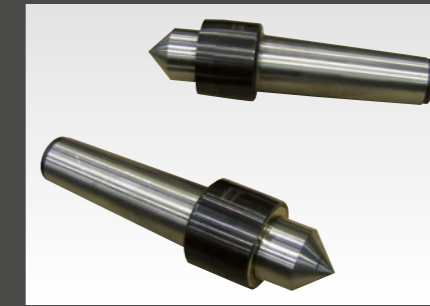

Centers



Anchoring material



Carrier



Balancing arbor



Wheel flange



Dresser

## THE MOST SUITABLE SOLUTION FOR GRINDING IS POWER PANEL 900:

- ✓ Cost-effective solutions
- ✓ Controller was developed directly for grinding machines
- ✓ Openness and flexibility for customer requirements
- ✓ Easy to use, support for fully automatic and manual work
- ✓ Human machine interface was developed exactly for our machines with the intention for easy and effective control
- ✓ Touch panel for fast and effective work!

## POWER PANEL 900 AT GLANCE:

- ✓ 18,5 TFT C HD flat screen
- ✓ Touch screen (capacitive)
- ✓ 4x USB 2.0, (1x on front panel)
- ✓ 2x RS-232, 2x Ethernet 1/100/1000 and Power-Link for communication with drives
- ✓ Drives: AcoposMulti
- ✓ IP65
- ✓ Intel Atom

## TECHNOLOGY CYCLES:

- ✓ Longitudinal grinding
- ✓ Plunge cut grinding
- ✓ Multiple plunge cut grinding
- ✓ Taper grinding (cone)
- ✓ Convex/concave grinding
- ✓ Dressing

## SPECIAL CHARACTERISTICS OF CYCLES

Other hardware devices allow the use of special properties of grinding cycles.

- ✓ Measurement control, correction of contour and final diameter
- ✓ Asynchronous dressing of grinding tool
- ✓ Touch trigger probe
- ✓ Grinding acoustic sensor
- ✓ Automatic compensation of grinding tool
- ✓ Manual activation sparking – out stroke
- ✓ Manual activation stroke to workpiece
- ✓ Inside and outside grinding is possible

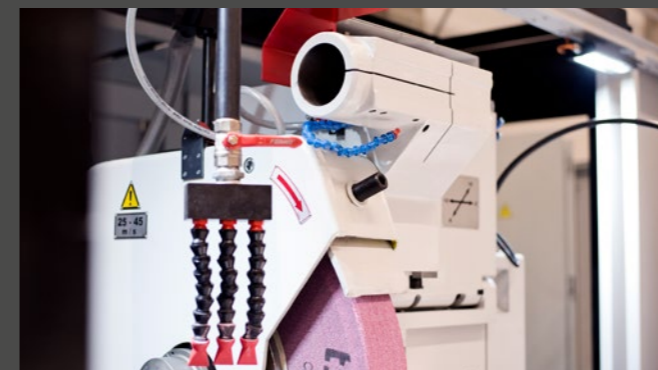

Internal grinding attachment

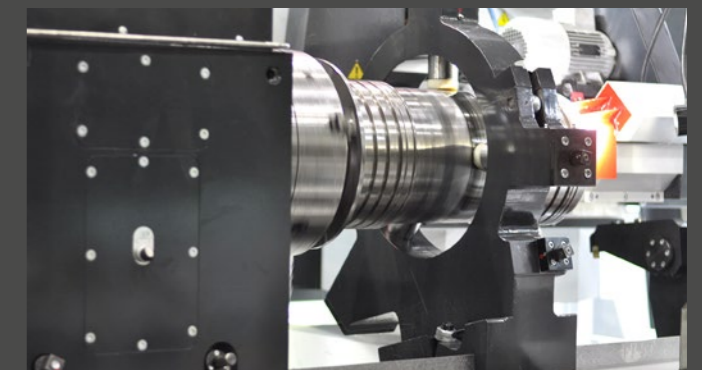

Closed rest



Ancillary restraints



Dresser

# SPECIAL ACCESSORIES

## SUPERFINISHING ATTACHMENT

Electrically powered tape finishing attachment for mounting onto medium and large carrier machines to enable superfinishing of ground and fine-turned surfaces. Well-suited for machining workpiece collars with radii or very small relief cuts. Apart from cylindrical workpieces, flat surfaces can also be machined.

Usually 0,05 Ra

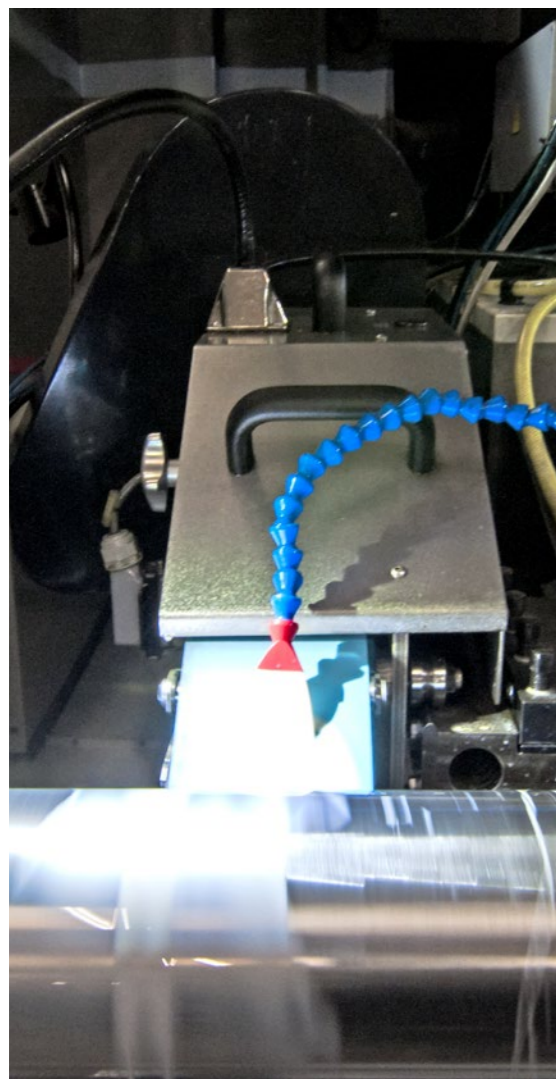

## AUTOMATIC BALANCE SYSTEM

The VM25 is a modular multifunction system for grinding processes. It is a single integrated unit for automatic balancing during grinding. Automatic balance system is placed on the grinding wheel cover and the process of automatic balancing is controlled at the screen on the control system panel.

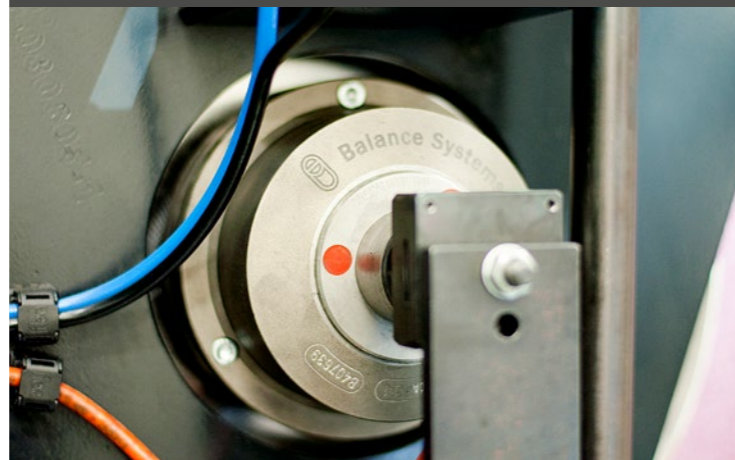

## CAMERA

The machine can be equipped with a special camera, which is used for working space scanning. The view is displayed at the screen of control panel.

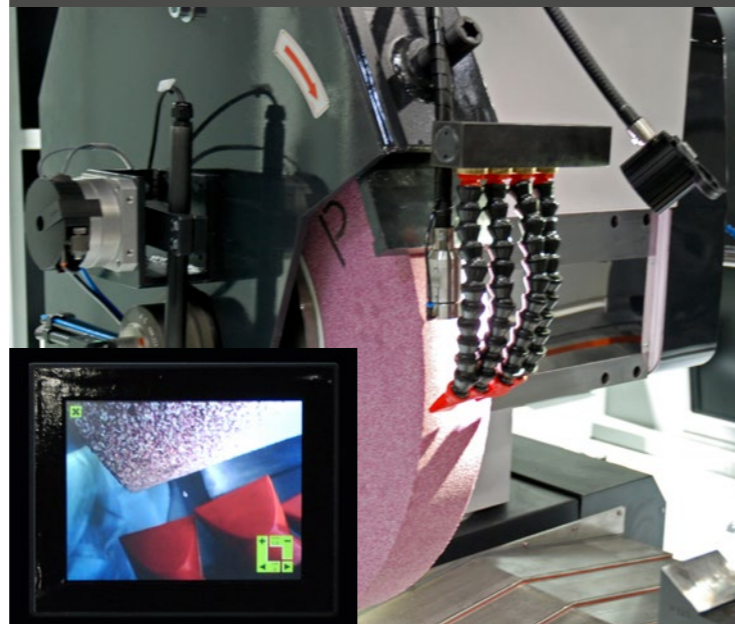

## MEASURING SYSTEMS

Axial probe Heidenhain TS 260

We recommend to equip the machine with the axial probe Heidenhain. It is used for setting of workpieces in serial production.



## MEASURING SYSTEMS

The machine can be equipped with a wide-range in-process gauge Protomar from Marposs or TGA from Balance Systems. The gauge is located on the portal mechanism, which can be controlled independently in several axes. The use of inprocess gauge substantially shortens the time required to grind the workpiece by eliminating idle time for manual measurement. Furthermore, the gauge ensures the stability of accuracies throughout the series by setting predefined dimensions.

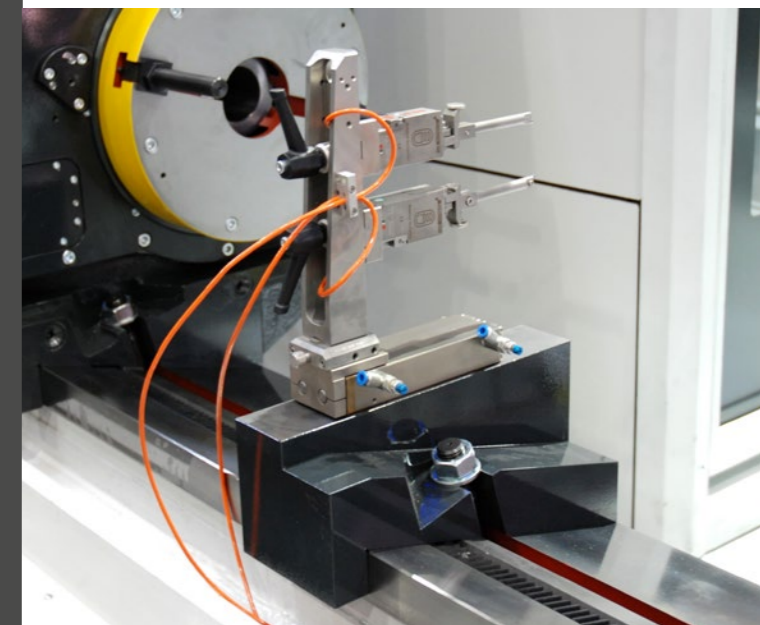

# COMPONENTS

MANUFACTURER

**SIEMENS** 

**HEIDENHAIN** 

**RITTAL** 

**TriboTec** 

**FESTO** 

**LAPP GROUP** 

**RÖHM** 

**KSK KURIM** 

MANUFACTURER

**HESTEGO** PROTECTION SYSTEMS 

**FOINJA** SPOL. S R.O. STRAKONICE 

**SKF** 

**ASTOS** CHIP CONVEYORS AND FILTRATION 

**INA FAG** 

**TYROLIT** 

**LEHMANN** UMT 

**Balance Systems** 

**FILTERMIST** 

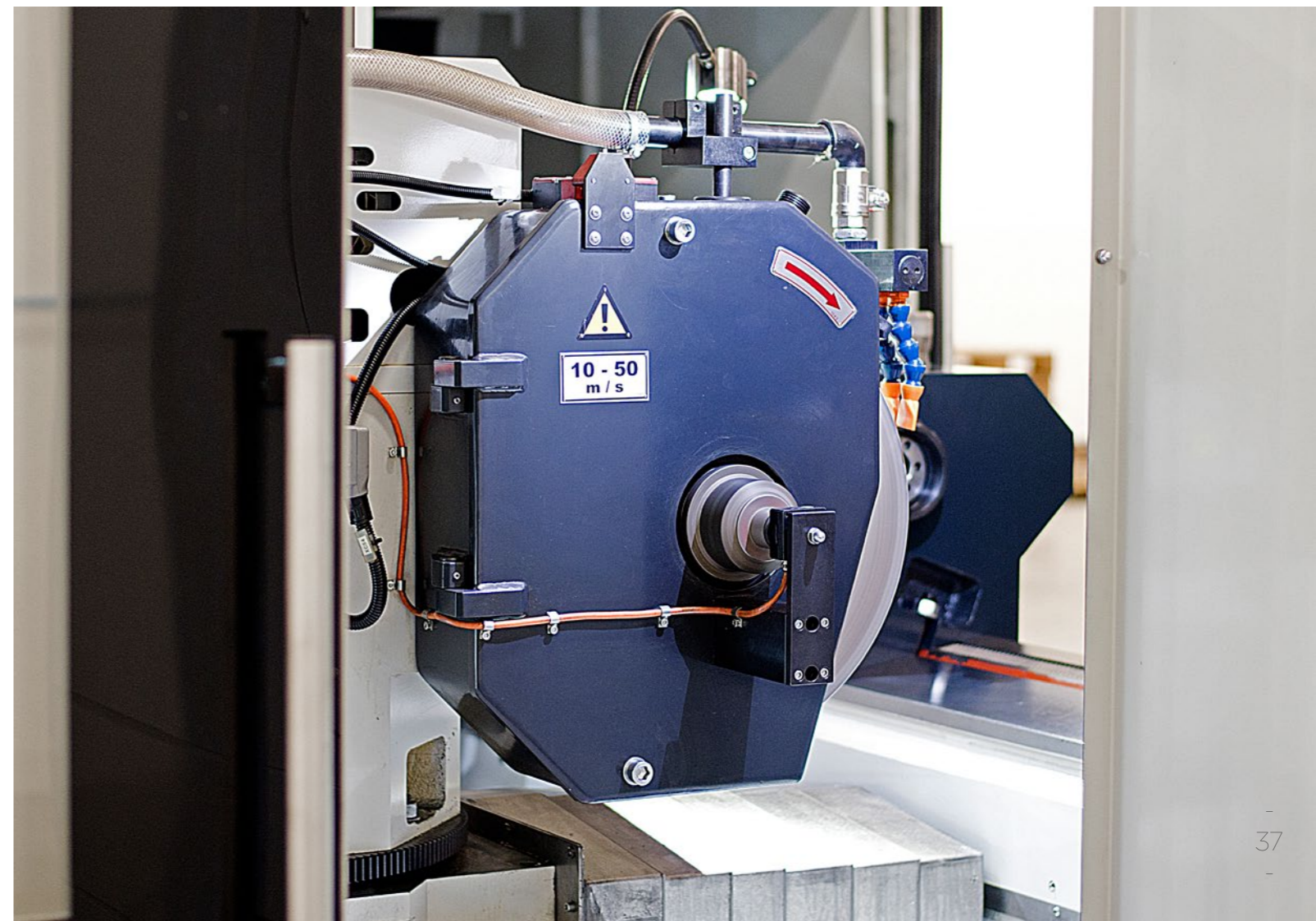
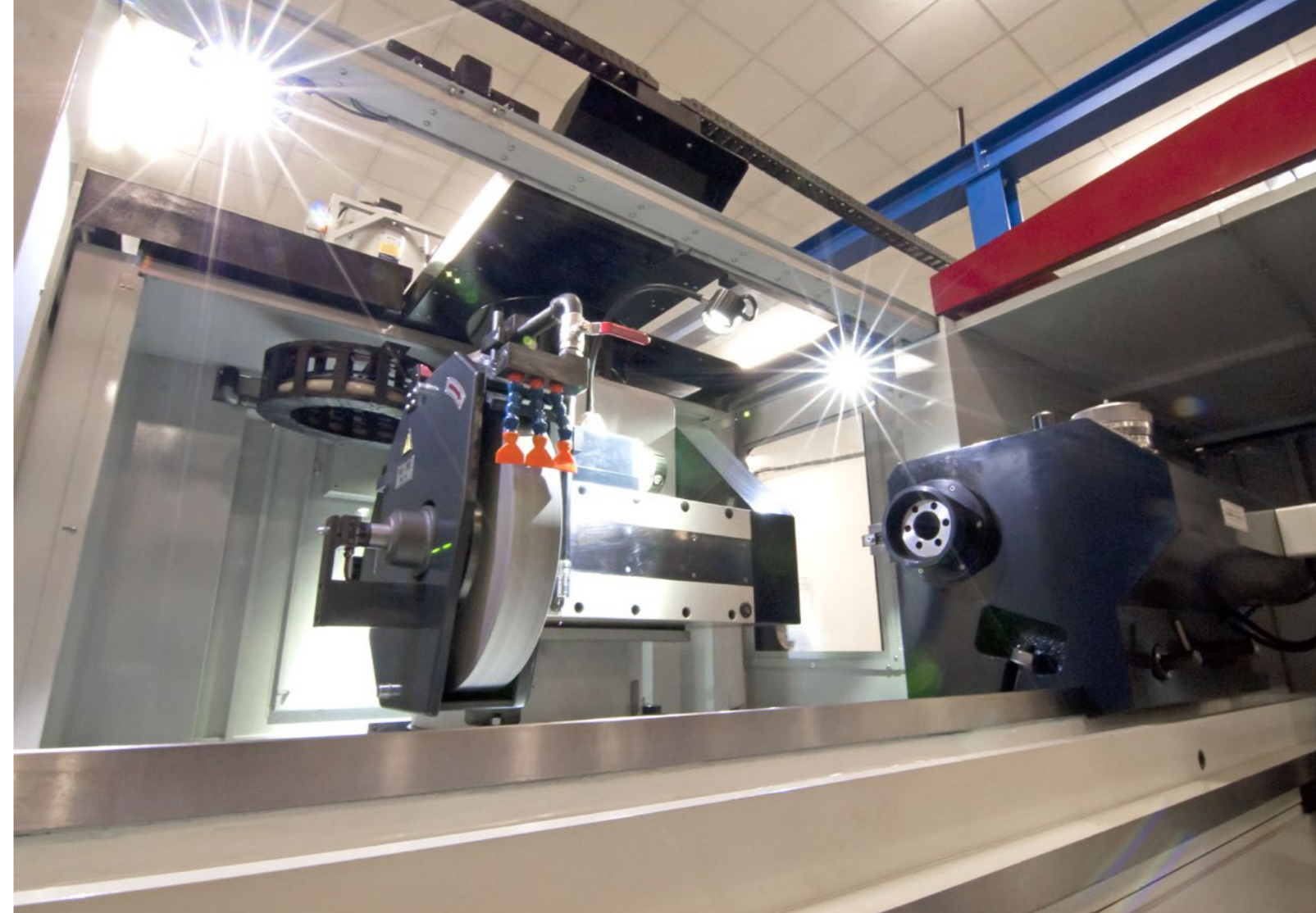

# BUC E

BUC E is a fully CNC controlled grinding machine designed for longitudinal and plunge-cut grinding of cylindrical and conical external surfaces, or with internal grinding attachment for grinding of cylindrical and conical internal surfaces.

Grinding of face surfaces can be performed by the side of grinding wheel or its circumferential surface using work head swivel.

Grinding machine series BUC E can be used particularly in single-part and series production for grinding of workpieces up to 3000 kg. The machine is produced with higher accuracy to enable grinding of single diameters in the tolerance of IT 4 and higher. Standard version of the machine is equipped with Siemens 828D sl, Siemens 840D sl or B&R control systems. The machine meets CE standards and is supplied with essential accessories and a guarantee of 1 year.

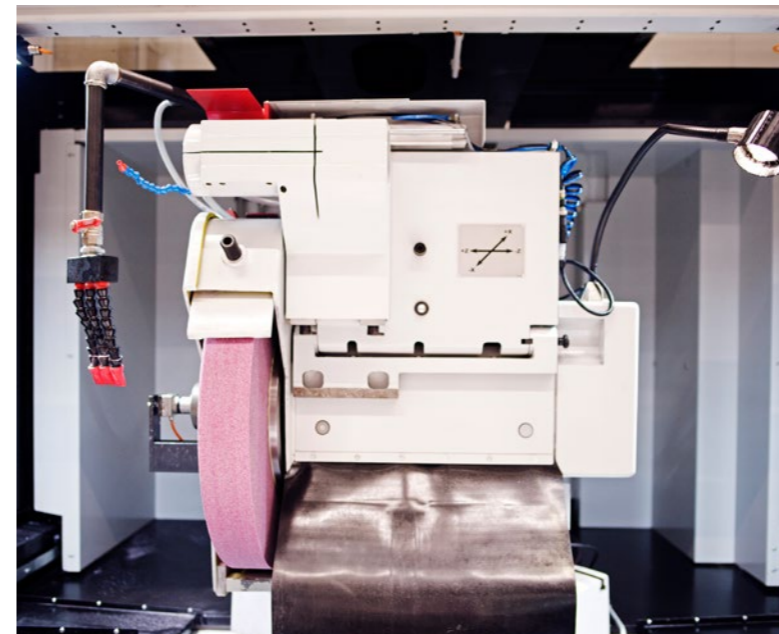
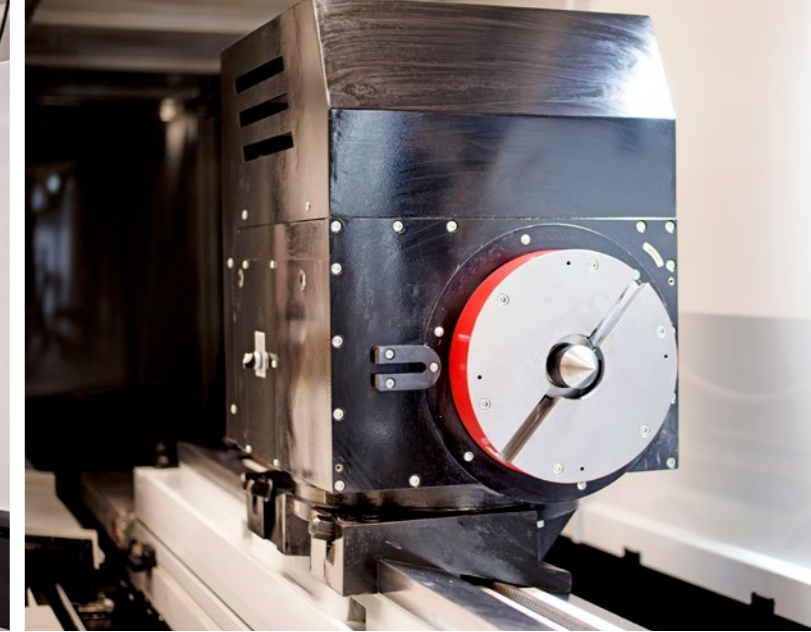

PARAMETERS	Units	Design version
Swing diameter	mm (in)	630 (24,8) / 850 (33,5)
Distance between centers	mm (in)	2000 (78,7) / 3000 (118,1) / 4000 (157,5) / 5000 (196,8)
Max. weight of workpiece-between centers	kg (lb)	3000 (6600)
Max. weight of workpiece-with live spindle (incl. clamp)	kg (lb)	300 (660)
Minimum programmable in-feed – Axis X	mm (in)	0,0005 (0,00002)
Maximum speed	m.min <sup>-1</sup> (in/min)	10 (393,7)
Minimum programmable table feed – Axis Z	mm (in)	0,001 (0,00004)
Maximum speed	m.min <sup>-1</sup> (in/min)	10 (393,7)
Table indexing	°	+6/-5, +5/-5, +4/-4, +3/-3
Grinding wheel dimensions (dia. x width x bore)	mm (in)	Ø 750 x 100 x Ø 305 (Ø 29,5 x 3,9 x Ø 12)
Maximum grinding wheel width	mm (in)	125 (4,92)
Grinding wheel peripheral speed	m/s	25 - 45 (10 - 50 option)
Wheel head swivel	°	+30/-10
Wheel head motor power	kW (hp)	18,5 (24)
Tailstock barrel stroke	mm (in)	80 (3,1)
Cross motion of tailstock center - cylindrical correction	mm (in)	±0,8 (0,031)
Tailstock clamping force	N	300-12000

Other specifications		
Length of machine	mm (in)	8500 (335) / 10600 (417) / 13000 (512) / 15500 (610)
Width of machine	mm (in)	4400 (173)
Height of machine	mm (in)	2888 (100)
Weight of machine	kg (lb)	14000 (30800) / 16000 (35200) / 19000 (41800) / 22000 (48400)



# BUB E

BUB E is a fully CNC controlled grinding machine designed for longitudinal and plunge-cut grinding of cylindrical and conical external surfaces, or with internal grinding attachment for grinding of cylindrical and conical internal surfaces. Grinding of face surfaces can be performed by the side of grinding wheel or its circumferential surface with using work head swivel.

Grinding machine series BUB E can be used particularly in series and large series production for grinding of workpieces up to 500 kg. The machine is produced with

higher accuracy to enable grinding of single diameters in the tolerance of IT 4 and higher. The standard version of the machine is equipped with Siemens 840D sl or B&R control systems. The machine meets CE standards and is supplied with essential accessories and a guarantee of 1 year.

The machine can be specially equipped with a B axis with multiple wheels, teflon guideways, C axis for grinding non-circular shapes and other advanced accessories. In addition, a monolithic table design can be selected to increase stability



See BUB video

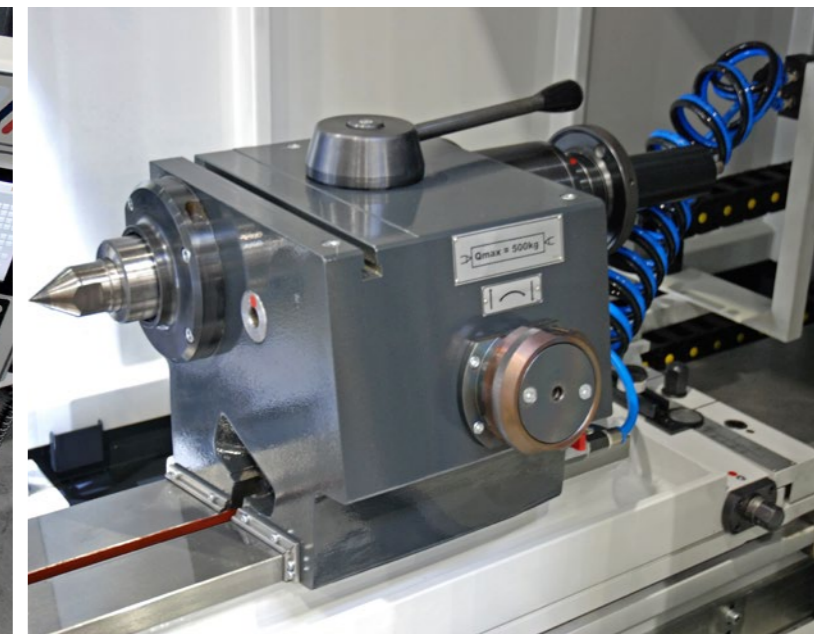
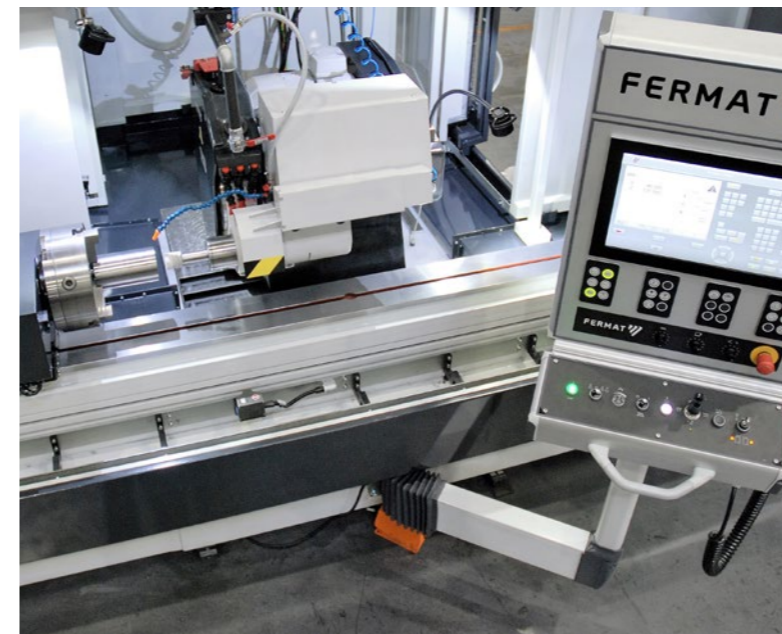
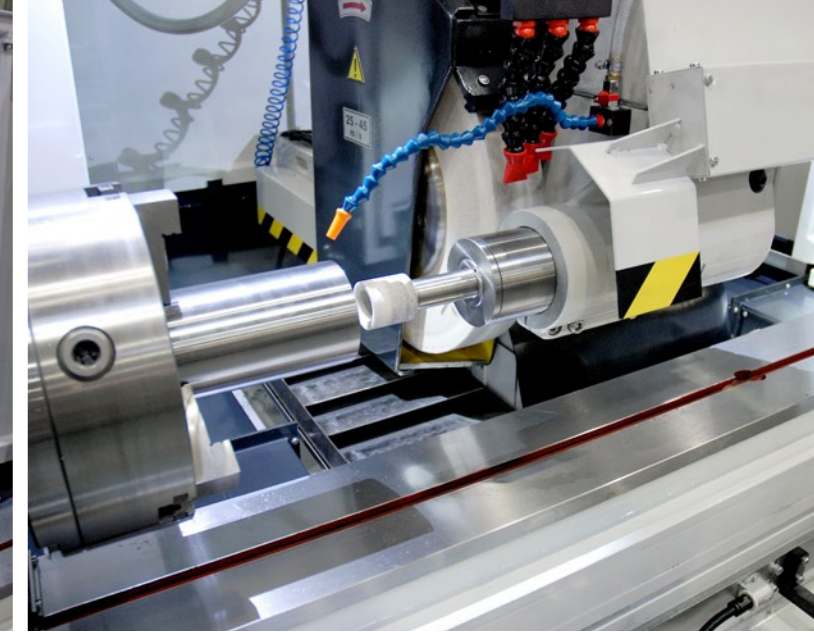

PARAMETERS	Units	Design version
Swing diameter	mm (in)	320 (12,6) / 400 (15,7) / 500 (19,7) / 600 (23,6)
Distance between centers	mm (in)	1000 (39,4) / 1500 (59) / 2000 (78,7) / 3000 (118,1)
Grinding wheel dimensions	mm (in)	Ø 500 x 80 x Ø 203 (Ø 19,7 x 3,1 x Ø 8)
Maximum grinding wheel width	mm (in)	125 (4,92)
Grinding wheel peripheral speed	m.s <sup>-1</sup>	25 - 45 (10 - 50 option)
Grinding wheel head swivel	°	+45/-15
Minimum programmable in-feed - Axis X	mm (in)	0,0005 (0,00002)
Minimum programmable in-feed - Axis Z	mm (in)	0,001 (0,00004)
Table maximum speed	m.min <sup>-1</sup> (in/min)	8 (314,9)
Max. weight of workpiece – between centers	kg (lb)	500 (1100)
Max. weight of workpiece-with live spindle (incl. clamp)	kg (lb)	80 (176)
Main electric motor power output	kW (hp)	11 (15)
<b>Machine dimensions</b>		
- Length	mm (in)	4900 (193) / 6600 (260) / 7700 (303)
- Width	mm (in)	3100 (122)
- Height	mm (in)	2200 (87)
Machine weight	kg (lb)	5800 (12760) / 6300 (13860) / 6800 (14960)
Ball screws		KSK Kuřim Shuton
Cooling and filtration		Astos Aš UMT LEHMANN
Lubrication		Tribotec
Pneumatic equipment		FESTO



## OTHER PRODUCTS

### TABLE TYPE HORIZONTAL BORING MILLS

WFC 10, WFT 11, WFT 13 and WRFT 130 (150, 160) represent the table type of horizontal boring mills. Chief machine characteristics are a powerful milling and drilling chip removal rate (even with top Y-axis stroke) and higher precision than other machines available on the market. A modular concept allows great operational variability in configuration, built according to the client's requirements. Modern control systems provide very easy operation of the machine and many useful functions for

the user. Horizontal Boring Mills WRFT and WFT 13 offer 5 linear axes travel (X, Y, Z, V, W) and 2 rotary axes (B and C) while WFC 10 and WFT 11 adopt the movement on 4 total axes. Given additional optional accessories, it is possible to increase the number of controlled axes. During the metal processing, the column of the machine adopts Z-axis movement (with the exception of the WFC model) and the workpieces are clamped on a rotary table that travels in the X-axis.



WFT 13



WFT 13  
+ robot



WRFT 150



WRF



WRF 130  
Portable



WFT 11



WFC 10



WF 13



WRF 160  
Heavy

## OTHER PRODUCTS

### FLOOR TYPE HORIZONTAL BORING MILLS

One of the main characteristic of the FER-MAT floor type horizontal boring and milling machines is their powerful milling and drilling chip removal (even at the top of the Y axis stroke) and higher precision than is offered by other machines available on the market. The large variation of selectable parameters is combined with its broad range of operating functions. The main feature is a modular concept that allows for greater production variables and rapid set-up through the use of peripheral tools and accessories. The machine moves in 3 or 4 different axes (X, Y, Z and W for borers). An additional B and/or V-axis is added when the machine is equipped with

the rotary table. Several clamping plates can be joined together, or combined with a rotary table to achieve specialized configurations easily and quickly. Work pieces can be clamped either on the additional rotary table, on the clamping plates, or using both these possibilities. The main working purpose of the machines is chip removal from large and heavy steel, cast steel, or cast iron work pieces. The machine's technology allows a wide utilization in milling, boring, reaming, and threading processes. FERMAT machines stand out thanks to their capacity to achieve higher precision than those of their competitors.

# REFERENCES

CYLINDRICAL GRINDING MACHINES

Hans Scharpegge GmbH, Germany

BHCR 85/4000 CNC



# REFERENCES

CYLINDRICAL GRINDING MACHINES

BONATRANS GROUP, a.s., Czech Republic

BHCR 63/3000 CNC (BHC 63/3000 CNC, 2x BUC E 63/3000 CNC)



NIVA-HOLDING, Belorussia

BHM 50/2000 CNC



TeroLab Surface GmbH, Germany

BHC 63/4000 CNC (BUC E 63/3000 CNC, 2x BUC E 63/4000 CNC, 2x BUB E 50/2000 CNC)



# REFERENCES

CYLINDRICAL GRINDING MACHINES

Jansen & Zühlke GmbH Oberflächentechnik, Germany

BHCR 100/4000 CNC

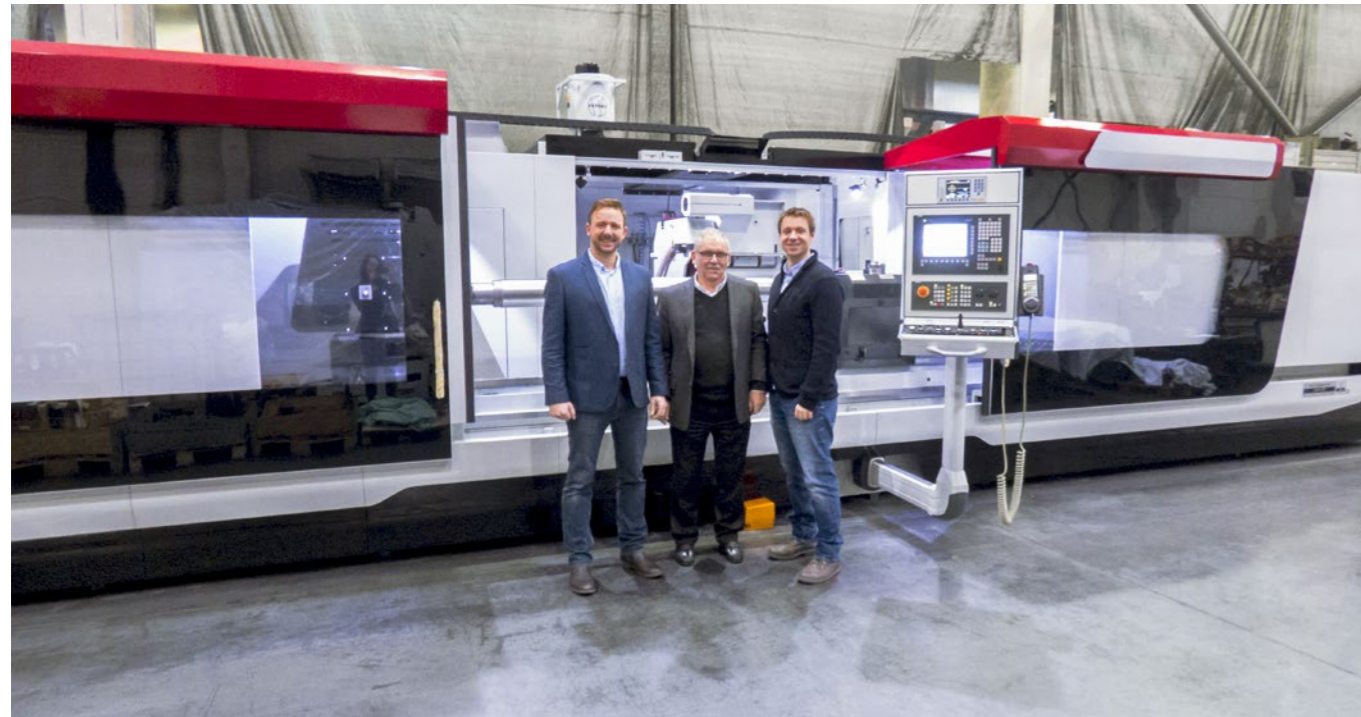

# REFERENCES

CYLINDRICAL GRINDING MACHINES

KONŠTRUKTA-Industry, a.s., Slovakia

BUB E 40/2000 CNC

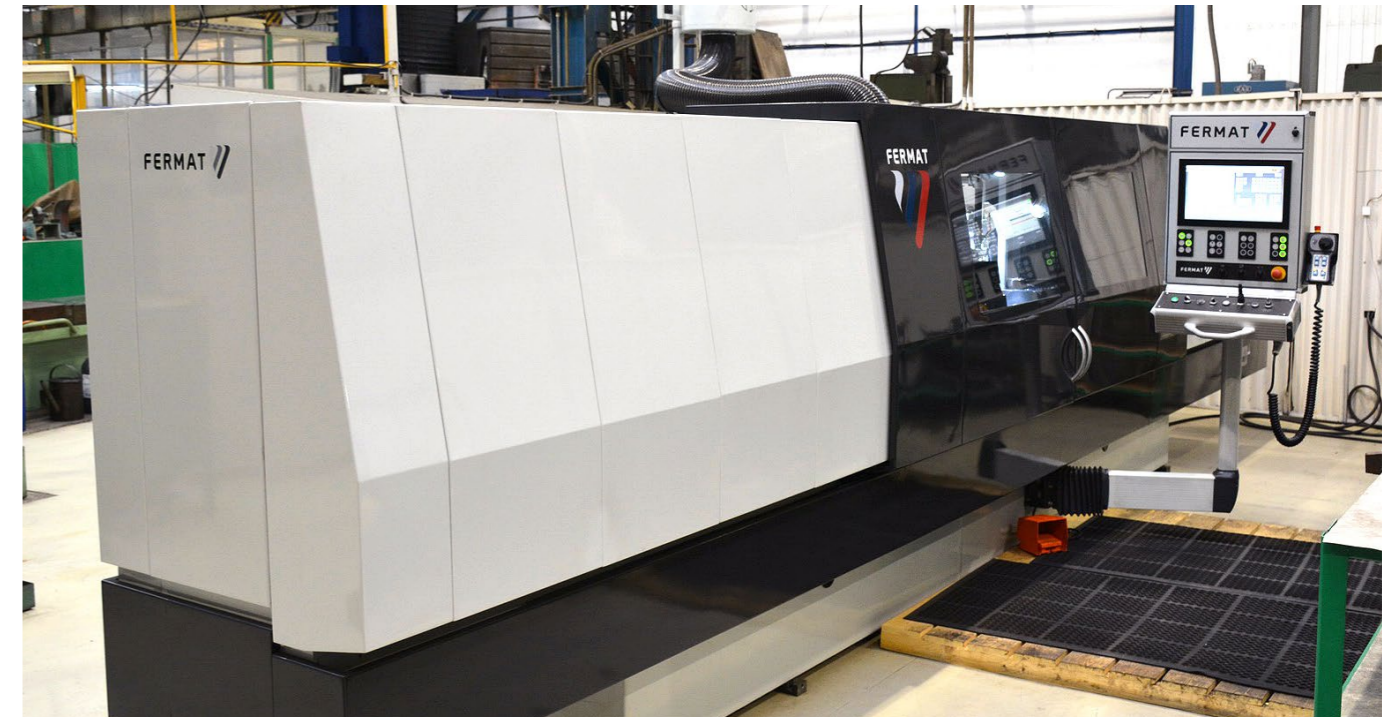

AO Tyazhmash, Russian Federation

BHC 63/4000 CNC



Herbert Hänchen GmbH & Co., Germany

BUB E 40/2000 CNC

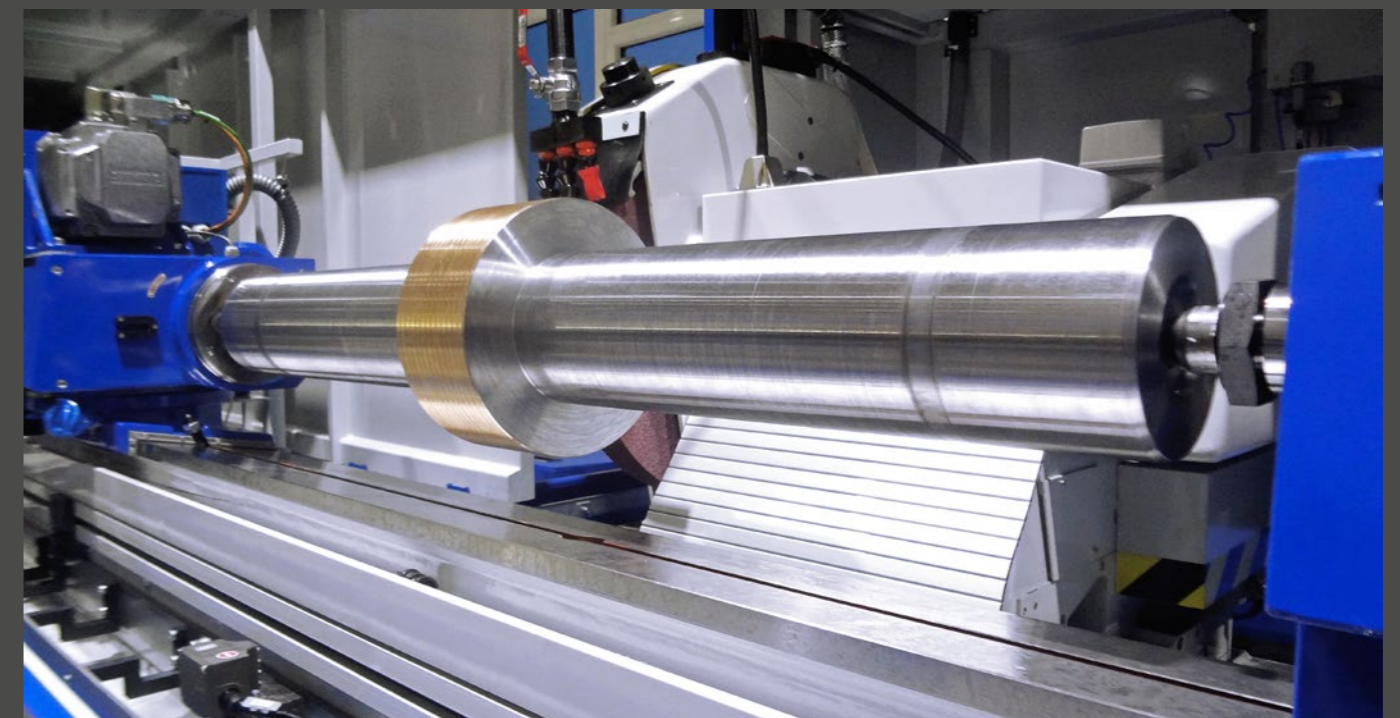





**FERMAT Machine Tool, s.r.o.**

Zitavskeho 496  
156 00 Praha  
Czech Republic

# GRINDING MACHINES

---

*Production hall:*

FERMAT Machine Tool, s.r.o.  
Radějovice 120  
251 68 Radějovice, Prague  
Czech Republic

*Customer Service Department*

E-mail: [grind@fermatmachinetool.com](mailto:grind@fermatmachinetool.com)

[www.fermatmachinetool.com](http://www.fermatmachinetool.com)  
[www.fermatmachinery.com](http://www.fermatmachinery.com)

